

**Research Report 2019**

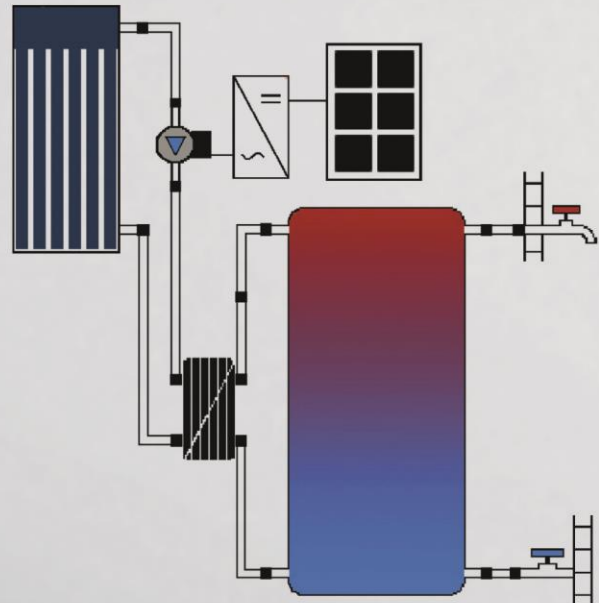

The comparison of simulation and experiment is well established in the field of research. The deviation of numerical calculation and measurement is also discussed during the study programme. Students participating in the Energy and Environment course use the experimental set up (left) to analyse the heat flows in a solar facility. In the simulation exercises they use the planning tool Polysun to simulate the same construction in a numerical model (right).

# Foreword

This institute report continues the tradition of the ICP of summarizing the research projects in an annual report. In addition to the activities in the main research areas of the ICP, projects from the teaching are now also presented. Digitalization is changing not only research and industrial engineering, but also teaching methods at universities of applied sciences. We are observing how our students come into lectures with powerful and handy mobile devices. On the one hand, this brings us a significant step closer to paperless study. A beautiful blackboard picture is photographed and can be found seamlessly in the digital notes next to teaching materials provided on Moodle. On the other hand, an old ICP-dream is coming true: simulations have arrived in class! Using numerical experiments, we can make physical processes available to the students that would otherwise be intangible due to their dimensions. The large collection of analogue experiments - many of them from a time when our school was still called *Technikum Winterthur* - is supplemented by *digital experiments*. Simulations can be carried out on the students' mobile devices, activate the students, arouse their curiosity and help to illustrate complex interrelationships. We are pleased to be able to make an active contribution to the expansion of the physics collection with our computer experiments on behalf of the ICP. We are aware that the use of mobile devices for these purposes brings not only obvious opportunities but also didactic challenges. A large third-party-funded project of the International Lake Constance University IBH deals with this topic under the didactics slogan *Seamless Learning*; it is described in chapter 5.2.

We are confident that with our simulations we will increase the quality of basic education and awaken students' interest in applied and industry-related research. The results of these projects are presented in the first four chapters of this report. Thanks to all researchers for their commitment to science and for the highly interesting articles that summarize their activities.

Andreas Witzig, Head of Institute, April 2019

# Table of Contents

<b>Foreword</b> .....	<b>I</b>
<b>1 Multiphysics Modeling</b>	<b>1</b>
1.1 Powder Coating: Simulation-Based Prototype Development of a Novel Powder Coating Gun Generation, Based on Targeted Adaption of the Coronal Field.....	2
1.3 Wood Gasification – From ICP to Melides, Portugal.....	4
1.4 Impact of Fouling on Mechanical Resonator-Based Viscosity Sensors.....	5
1.5 Model of a Decanter Centrifuge to Predict the Settling Behavior of Particles in Solid-Liquid Suspensions.....	6
1.6 Analyzing the Thermal Behavior of the Medyria Velocity Sensor Based on an OpenFOAM Thermo-Fluidic CFD Model .....	7
1.7 Multi-Scale Model of Crystal-Polymorphism .....	8
1.8 Powder Coating: A Post Processing Tool to Analyze Powder Coating Thickness Data.....	9
1.9 Test Bench for Contactless Welding of Plastic Samples .....	10
1.10 Dynamic Delamination in Morphing Blades and Wings .....	11
1.11 Spectral Composition of the Faraday Instability in Small Vessels .....	12
1.12 PVT-Hybrid Collectors: Heat and Electricity from the Sun.....	13
<b>2 Electrochemical Cells and Microstructures</b>	<b>14</b>
2.1 Simulating the Energy Yield of Next Generation Photovoltaics .....	15
2.2 Analyzing the Dynamic Response of Perovskite Solar Cells.....	16
2.3 Advanced Characterization of Fuel Cell Stacks for Automotive Applications (ACTIF).....	17
2.4 Experimental Parameter Uncertainty in Polymer Exchange Membrane Fuel Cell Modeling.....	18
2.5 Modelling and Simulation of an Organic Redox Flow Battery Cell .....	19
2.6 Modeling and Simulation of a Hydrogen-Bromine Redox Flow Battery Cell.....	20
2.7 Microstructure Evolution upon High Temperature Corrosion of Metallic Interconnectors (MIC) for Solid Oxide Fuel Cells (SOFC) .....	21
2.8 Model to Predict Degradation-Optimized Operation of High-Temperature Fuel Cell Stacks .....	22
<b>3 Organic Electronics and Photovoltaics</b>	<b>23</b>
3.1 From Lab to Fab: Upscaling of Perovskite Solar Cells .....	24
3.2 Ultrabroadband THz Photonics Based on Organic Crystals.....	25

3.3	Dye-Sensitized Solar Cells: Simulation of the Impedance, Experimental Validation and Parameter Extraction .....	26
3.4	Improved Luminous Efficacy in Organic Light-Emitting Diodes Thanks to a Newly Developed Diffusion Layer .....	27
3.5	Limits of Triplet Harvesting in Fluorescent Organic Light Emitting Diodes .....	28
<b>4</b>	<b>Sensor and Measuring Systems</b>	<b>29</b>
4.1	Skinobi – an Affordable Sensor to Track Skin Condition and Age.....	30
4.2	3D-Thermography for Medical Applications.....	31
4.3	Portable Device for Early Diagnosis of Lymphedema.....	32
4.4	DermaIR – Increasing the Capabilities of Dermatoscopy Using Thermal Imaging Sensors.....	33
4.5	Modelling of Ground-Source Coil Tanks for Thermal Analysis .....	34
4.6	Digital Twin: Using Building Information Modelling (BIM) for Simulation of Building-Integrated Energy Systems .....	35
4.7	Measuring Thermal Coating Resistance of Turbine Blades .....	36
4.8	Viscosity Control Technologies for the Controlled Application of Coating Materials .....	37
<b>5</b>	<b>Teaching</b>	<b>38</b>
5.1	Gamification in Teaching .....	38
5.2	Seamless Learning Project Cluster and Management of the IBH Lab.....	42
<b>Appendix</b>		<b>45</b>
A.1	Students Projects .....	45
A.2	Scientific Publications .....	46
A.3	Book Chapters.....	48
A.4	News Articles .....	48
A.5	Conferences and Workshops .....	48
A.6	Teaching.....	49
A.7	Spin-off Companies.....	51
A.8	ICP Team .....	53
A.9	Location.....	54

# 1 Multiphysics Modeling

Multiphysics modeling is a powerful tool for exploring a wide range of phenomena, coupling flow, structure, electro-magnetic, thermodynamic, chemical and/or acoustic effects. The past decades have been a period of rapid progress in this area. In fact, a Google search of this neologism returns more than 11,600,000 results. The possible range of applications has been widely expanded and numerical methods have become increasingly sophisticated and adapted to exploit available computational resources. Today, detailed physical-chemical models combined with robust numerical solution methods are almost a necessity for the design and optimization of multifunctional technical devices and processes.

At ICP, we perform applied research in the field of multiphysics modeling and develop finite element, as well as finite volume simulation software.

Our extensive experience in numerical analysis, modeling and simulation covers nearly all types of micro-macro devices and a wide range of governing equations of classical physics. We also develop single-purpose numerical tools specifically tailored to the needs of our partners, or use commercial software if better suited.

Among our specialities in this context is the application, extension and development of coupled models within our FE-inhouse code SESES, the CFD open-source software openFoam and/or commercial products such as COMSOL Multiphysics.



Christoph Bader



Gernot Boiger



Marlon Boldrini



Daniel Brunner

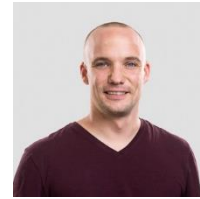

Vincent Buff



Sandro Ehrat



Thomas Hocker



Lukas Keller



Viktor Lienhard

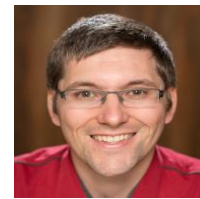

Philip Marmet



Yasser Safa



Bercan Siyahhan



Sebastian Spirig



Asier Zubiaga

## 1.1 Powder Coating: Simulation-Based Prototype Development of a Novel Powder Coating Gun Generation, Based on Targeted Adaption of the Coronal Field

**An additional electric field near the nozzle outlet exploits the charge of powder particles to deflect particle trajectories without moving the coating gun itself. Simulation-based and experimental proof-of-concept are established. Parameter studies are being conducted and will lead to a functional pre-prototype as project deliverable.**

Contributors: G. Boiger, M. Boldrini, V. Lienhard, B. Siyahhan, V. Buff, J. Gianotti

Partners: Wagner International AG

Funding: Direct

Duration: 2018–2019

Based on prior and ongoing Innosuisse Projects with Wagner, this independent project focuses on deflecting and directing a powder cloud without moving the coating gun itself. Within the scope of the Innosuisse projects, tailored powder coating simulation has been developed and still undergoes further development. Simulation-based corona shape prediction considering gun geometries and other influences, allow i) targeted modifications of corona shapes, ii) influence particle trajectories and iii) optimization of powder coating results. The project aims for targeted modification of the governing electric field between coating gun and substrate, solely by constructional means in and attached to the powder coating gun, thus i) varying the focus of local coating intensity without moving the gun, ii) minimize areas with low coating quality and iii) maximize coating efficiency.

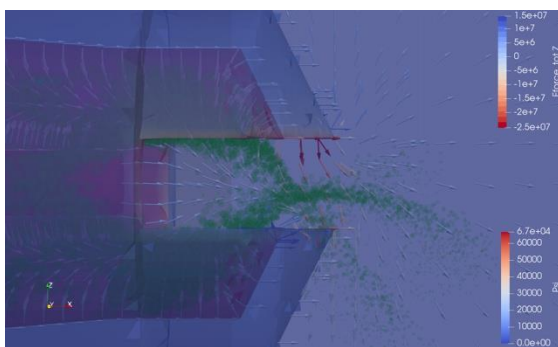

Fig. 1: Close up on coating gun nozzle. Concept simulation of particle (green) trajectories with imposed additional voltage between upper and lower part of the slit, resulting in a downward acceleration of the charged powder particles.

The main approach exploits particle charge, redirecting the trajectories by added electric fields. The deflection depends on strength and direction of the applied electric field. Initially, several concept stud-

ies have been performed in order to assess feasibility and governing forces in the relevant areas (see Fig.1). First, a capacitor model has been introduced, imposing variable electric potentials to upper and lower nozzle outlet areas. The deflection is proportional to the capacitor area and inversely proportional to capacitor distance. Prestudies showed that feasible deflection occurs in the range of 10-50 kV, which is well within the order of magnitude of the overall coating operation voltages.

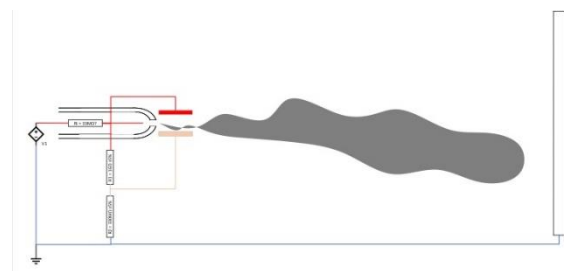

Fig. 2: Capacitor imposes additional electric field perpendicular to particle trajectory.

The simulation-based proof-of-concept is leveraged to a safely operational experimental setup. Nozzle attachments introducing isolated capacitor plates in the slit outlet area were constructed (see Fig. 2). Experimental proof-of-concept was established in internal experiments. Simulation-based and experimental parameter studies are being conducted, leading to a functional pre-prototype.

## 1.2 Development of New All-Ceramic High-Temperature Heating Elements for Hot Air Generation Ready for Series Production

**In the follow-up project to Leister 1, the heating element developed in the previous project is further developed to production readiness. The work includes the further improvement of the OpenFoam® models, comparison with various test and measurement set-ups, up to the production-ready prototype with a clear manufacturing concept.**

Contributors: M. Boldrini, J. Gianotti, G. Boiger  
Partners: Leister Technologies AG  
Funding: Innosuisse  
Duration: 2015–2019

In this development project with Leister, a new heating element for hot air pistols is being developed. The new heating elements should be made from conductive ceramics. In terms of production costs and reliability, the ceramic elements should be superior to the current elements based on metallic heating wires. The development is carried out as a cooperation between the IMPE and the ICP. The IMPE focuses on the development of high-performance ceramics. The ICP develops several numerical calculation models, which enable the simulation and comparison of different heating element-geometry variants. This already led to the development of the double helix in 2017, which was equal to the complete success of the first project phase. In the next project phase, the double helix should now be brought to production maturity.

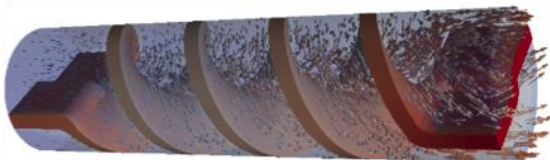

Illustration 1: Thermo-fluiddynamische Simulation des Heizelements in OpenFoam®.

For the further development of the heating elements ZPP was consulted as an additional competence centre. The ZPP focuses on the development and optimization of the manufacturing process.

The ICP pursues two main tasks in the current phase. On the one hand, geometry adjustments are checked on the basis of an OpenFOAM® - as well as an SESES model- in order to identify weak points and implement optimisations. On the other hand, measurement set-ups are also realized, which allow a precise insight into the existing boundary conditions. The first step was to implement a setup to measure the volume flow. With this, system and fan characteristics for different geometries can be determined, which serve for more precise validation and further improvement of the simulation models.

In the following steps, the geometry is to be further improved with regard to heat transfer, pressure loss and manufacturability up to the production-ready prototype.



Illustration 2: Different double helix geometry variants.



### 1.3 Wood Gasification – From ICP to Melides, Portugal

**In search of a sustainable method to reduce the non-native Eucalyptus population in Melides, Portugal, the ICP has been laboring alongside the Aberta Nova foundation. We are developing a prototype wood gasification reactor, which will operate almost without any tar production. The novel, low-maintenance gasification system shall be versatile enough to turn any type of wood chips into thermal energy, combustible gas and electricity.**

Contributors: G. Boiger, D. Neeser, A. Fassbind, P. Caels

Partners: Aberta Nova

Funding: Aberta Nova, internal

Duration: since 2016

Wood gasification is a potential core technology in the context of sustainable, decentralized heat and electricity supply for homeowners as well as small and medium businesses. For years, the ICP has conducted research in this field.

Since 2016 an ICP team has teamed up with the Portuguese Aberta Nova foundation to construct a prototype 20kWel- and recently a low-tar, low-maintenance 5kWel-gasifier at their site in Melides. While the aggregates from the beginning ran quite smoothly on Pine, Eucalyptus up until recently caused problems concerning long-term stationary operation. Among the main problems were (i) the high amount of excess thermal energy, released by the gasification reaction as well as (ii) unwanted tar condensation throughout the systems.



Figure 1: D. Neeser and G. Boiger (ICP) and P. Caels (Aberta Nova) working at prototype gasifier.

Since the summer of 2017, an ICP/ZPP gasification team, composed of D. Neeser, A. Fassbind and G. Boiger, has stayed at the Aberta Nova site for several weeks. Within this period the whole wood gasification system was mapped out, modeled [1], a gas-air-water heat exchanger was devised, tar condensation behavior was studied and a novel low-tar system was dimensioned. Based on this work and after careful planning and organizing necessary materials and tools, a prototype low-tar, low-maintenance 5kWel-gasifier was welded, assembled and put to operation. Figure 1 shows the ICP team,

working with P. Caels at the Aberta Nova site, while Figure 2 presents the CAD drawing vs. final state of our novel heat exchanger.

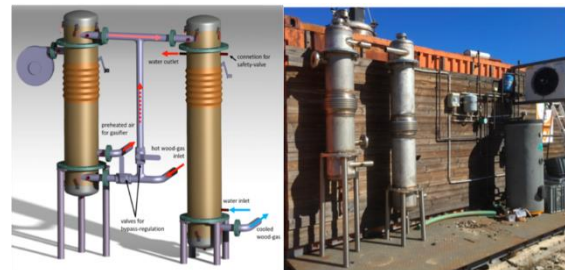

Figure 2: CAD scheme (left) of gasifier and actual result of our efforts (right).

Together with our Portuguese partners, led by P. Caels, the ICP researchers were thus able to achieve (i) assertion of full functionality of the novel low-maintenance gasifier, (ii) successful test runs showing stable operation with Eucalyptus, (iii) hardly any tar condensation in various test modes and (iv) an increase of electrical power output due to higher system efficiency based on higher reactor temperatures and cooler wood gas.

#### Literature:

[1] Boiger, G. (2014). [A thermo fluid dynamic model of wood particle gasification and combustion processes](#). IJM, Volume 8, Number 2. 203-230. Peer reviewed.

## 1.4 Impact of Fouling on Mechanical Resonator-Based Viscosity Sensors

**This study discusses a state-of-the-art online viscosity sensor, which is used in an environment subject to fouling. A fouling layer can contaminate the measurement and is a potential source of error. The effect of a fouling layer has been studied on a simplified fouling model numerically and experimentally.**

Contributors: D. Brunner, G. Boiger  
Partners: Rheonics GmbH  
Funding: Innosuisse  
Duration: 2018–2020

Monitoring viscosity in a chemical, biological or another industrial process is essential to maintain the quality of the process. In many industrial processes, the viscosity of a fluid is strongly related to the fluid's composition, hence the viscosity can be used to detect changes and proper countermeasures can be taken.

Nowadays, online integrated viscosity measurements are possible by using mechanical resonators. However, there are issues when deposits are built on the resonating structure. Fouling or the formation of deposits on the resonator are a potential threat, which can contaminate the measurement and yield in a wrong prediction.

In the presented study, a probe style resonator has been coated with copper, which is a simplified, purely elastic deposit model. Figure 1 shows the copper deposit on the resonating tip of the sensor.

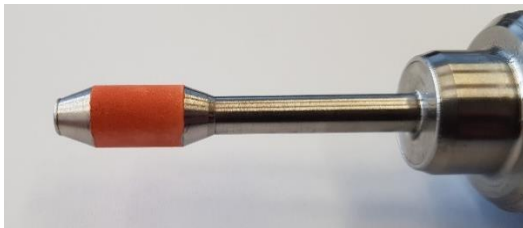

Figure 1: Resonator with fouling model (copper deposit).

The resonator has been mathematically approximated by a 2-mass 3-spring system. The fluid interaction has been modelled based on a 2-D model in COMSOL Multiphysics. Based on a flat surface, the viscous damping (represented by  $\Gamma$ ) would be slightly decreased purely by inertial effects of the fouling layer. However, the experiments indicate that the damping increases. Furthermore, the relative increase is more pronounced for low viscosity which breaks the typical linear behavior of the sensor.

These effects could be explained by surface roughness. The fouling layer may be flat on a macroscopic level; however, it shows a roughness in the micrometer scale. This roughness is in the order of magnitude of the characteristic length scale of the flow, hence carries significance. The roughness has been modelled by two sinusoidal wavy surfaces and can explain the characteristics of the measurements, see Figure 2. However, further investigations on the surface structure and 3-D flow simulations are needed to fully understand the phenomenon and make reliable predictions. Future studies will involve deposits encountered in industry such as CaCo<sub>3</sub> or paraffin.

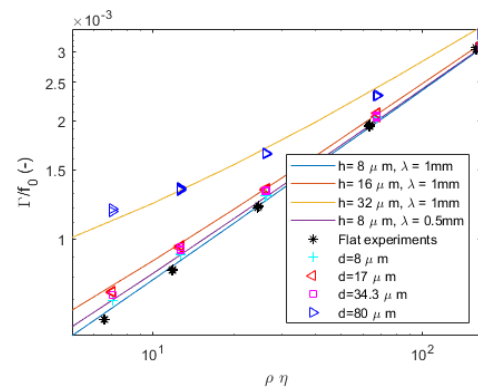

Figure 2: Comparison of experimental data to numerical predictions.

## 1.5 Model of a Decanter Centrifuge to Predict the Settling Behavior of Particles in Solid-Liquid Suspensions

Centrifuges are devices which employ a high rotational speed to separate components of different densities. Recently, Tilo Hühn and coworkers from ZHAW Wädenswil developed a completely new process for chocolate making where the cacao beans are crushed, dissolved in water and then separated in a decanter centrifuge. To support the optimisation of this process, a yet simple, but powerful model has been developed.

Contributors: T. Hocker, D. Wyss  
 Partners: T. Hühn, ZHAW Inhaltsstoff- und Getränkeforschung  
 Funding: preliminary study  
 Duration: 2018–2019

Separating the individual phases of suspensions by centrifuges is a common process in many industries. Often, solids and liquids are first merged together to perform some sort of extraction, i.e., dissolving certain components from the solid into the liquid phase. However, for further processing, these phases need to be separated again from each other. To run this separation process in a continuous mode, decanter centrifuges are particularly convenient. There, a screw drive is used to continuously discharge the collected solids. Fig. 1 provides a sketch of the main component of such a centrifuge.

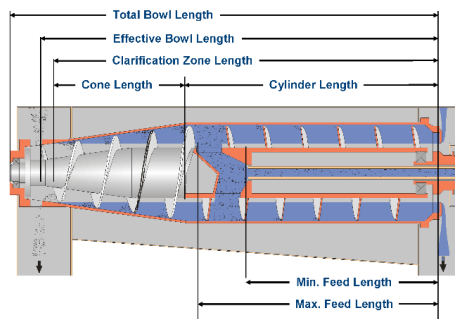

Fig 1: Sketch of a decanter centrifuge used to separate solids from liquids by exploiting their different densities.

To ensure a high degree of separation, bowl speeds of up to 5'000 rpm are used. Operating such centrifuges under steady-state conditions can be challenging, especially when the feed suspension changes its physical properties such as its viscosity or density. It therefore makes sense to use physical models to gain a better understanding of the settling process of solid particles from the suspension and how this is related to the properties of the feed as well as the geometry and operating parameters of the used centrifuge [1].

Fig. 2 shows a sketch of the simplified geometry on which our model is based. Here, the feed enters from the right. Due to higher density of the contained solids they settle at the inner wall of the bowl

– provided the flow velocity is not too large and the particles are not too small.

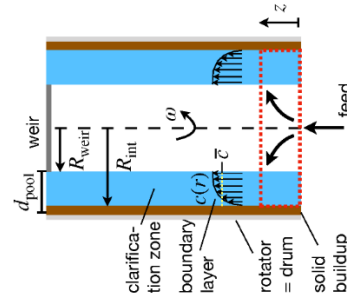

Fig 2: Simplified geometry for which the decanter model has been developed.

Using the well-known Stokes' settling theory as basis, we were able to derive a yet simple, but powerful model to predict the settling behaviour as well as the solids buildup and subsequent discharge. Fig. 3 shows typical model results at a certain point in time. Here, a feed containing six different particle sizes has been assumed. Besides the settling paths, the model predicts the solids buildup at the bowl wall shown as grey area.

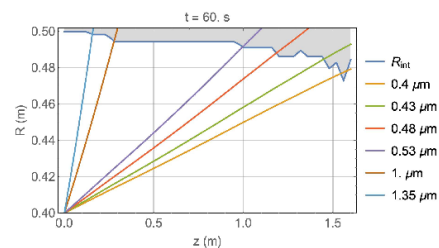

Fig 3: Particle settling paths and solids buildup predicted by the model for a feed containing six different particle sizes.

### Literature:

[1] M. Gleiss, S. Hammerich, M. Kespe, H. Nirschl, Chemical Engineering Science, 163, pp. 167–178 (2017).

## 1.6 Analyzing the Thermal Behavior of the Medyria Velocity Sensor Based on an OpenFOAM Thermo-Fluidic CFD Model

The *TrackCath* catheter developed by Medyria AG, Winterthur, has an integrated sensor to measure the flow-velocity and -direction in blood vessels. It has been observed that nominally equal catheters can exhibit significant deviations in their calibration curves. In order to better understand these deviations, a thermo-fluidic CFD-model was developed in *OpenFOAM*. The goal was to create an improved model setup to better determine the influence of the sensor properties and dimensions on the thermal behavior.

Contributors: L. Ruckstuhl; Advisor: T. Hocker  
 Partners: Medyria AG, Winterthur, M. M. Sette, A. Di Iasio  
 Funding: Master thesis  
 Duration: 2018–2019

The working principle of the sensor is the constant temperature anemometry (CTA). For a high measurement accuracy each sensor is calibrated separately. This is done by exposing the sensor to a water flow with given velocity and measuring the required electrical power to keep the sensor at a constant temperature. During a preliminary student project it was discovered that the set temperature of the sensor and the actual temperature on the surface were not identical. The surface temperature highly depends on the velocity of the flow and the isolation layer covering the heated area of the sensor. According to the sensor manufacturer layer variation of 10% (or  $0.5\ \mu\text{m}$ ) can be expected within one batch of sensors. As illustrated in Fig. 1 these deviations lead to a surface temperature variation of up to 6% at 2 m/s.

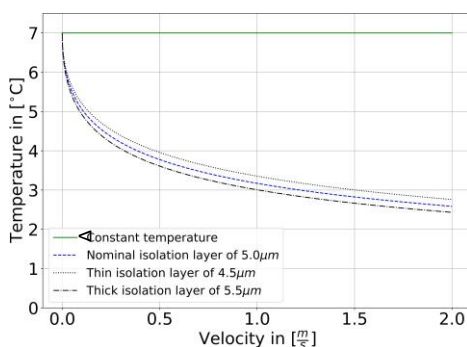

Fig. 1: The thermal behaviour of the sensor surface for different isolation thicknesses and flow velocities is illustrated.

In the preliminary model this surface temperature is a boundary condition, thus for each simulation first the occurring temperature needed to be calculated. This has disadvantages to use the model for predictions, because the velocity above the heating element might not be known or the heated area is changing in addition to the temperature. In order to improve that, a 2D CFD-model was developed, which in addition to the fluid includes the solid region of the sensor. Choosing a flat surface has the

following advantages: firstly, the surface temperature correlation is simpler for flat surfaces; secondly, the validation of the flow profile over a flat plate can be done using literature and, lastly, the mesh generation is simplified. In a later step, a 2D-model representation of the sensor on a cylindrical surface can be added if necessary. Fig. 2 shows a comparison between the calculated average surface temperature and the simulation results for two different flow velocities. The heated sensor area is indicated by the vertical red lines. The average surface temperatures correlate well with the simulation results.

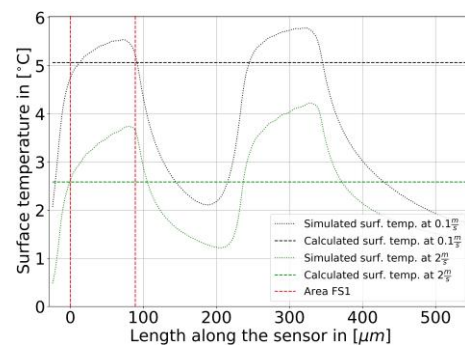

Fig. 2: A comparison between the calculated average surface temperature and the simulation results for two velocities is shown.

This supports the hypothesis that most of the variations observed between nominally identical catheters is due to their differences with respect to the isolation layer above the heated elements. As next steps, the thickness variations of the isolation layer will be further investigated by microscopy and resulting T-profiles will be assessed by thermal imaging.

## 1.7 Multi-Scale Model of Crystal-Polymorphism

**In the casting process, crystals nucleate and grow in multiple forms affecting the thermo physical properties of the materials. At macro-scale observation, the quality of the solid is influenced by both the thermodynamic and mass kinetic effects during crystallization. However, several static and kinetic effects are micro-scale players, they affect the material through a departure from the local thermodynamic equilibrium and cause undercooling phenomena. A new predictive approach is built through a coupled solving of the macro-scale heat-mass transfer problem and the micro-scale problem of grain solidification in undercooled melt. The new model shows the influences of local cooling rate as well as the surface curvature of the seeding crystal grains and nuclei on the temperature of the bulk material. With the new approach, the post-recalcescence solidification is computationally reproduced in agreement with the values from experimental measurements.**

Contributors: Y. Safa, T. Hocker

Partners: IFNH ETH Zurich, and Swiss chocolate manufacturing partners

Funding: Innosuisse

Duration: 2016–2018

The formation of polycrystals materials from a melt phase at high cooling rate promotes the nucleation and the growth of unstable crystal forms with limited latent heat release. In contrary, a low cooling rate promotes the growth of stable crystal forms accompanied by a large release of latent heat. Interconversion between different crystal polymorph and between melt and crystal take place. One can simplify the analysis of this problem by adopting a macro-scale model of heat-mass transfer system of equations to obtain the time-space distribution of the temperature and crystals. In such a simplified macro-scale model, interconversion between different crystal polymorph is represented as reaction equations with kinetic parameters (e.g. reaction constants) depending on the transition temperatures between phases in melt-crystals mixture. This simplified analysis comes on the expense of a realistic representation of the role of the cooling rate how it affects produced materials during moulding process. Indeed, a high cooling rate, is accompanied with melt undercooling of liquid phase below the melting point. This undercooling reflects a departure from the local thermo-dynamic equilibrium and influences the crystal formation. Different scenarios of interface undercooling including attachment kinetic and solute trapping at the interface were analyzed. Only the curvature undercooling was found pertinent to the chocolate solidification problem due to small size values of nuclei and seeding grains at given surface tension. Undercooling can be an interfacial phenomenon taking place on the surface of seeding crystal micro-grains and nuclei that are growing in a cooled or supercooled melt. The above simplified macro-scale model of heat-mass transfer cannot be a sufficient means to

capture such an interface undercooling between micro-grain and surrounding melt. Indeed a restriction to a micro-scale model is needed to capture the effects of interface undercooling. Such micro-model is formulated through Stefan problem in a melt micro-domain containing a spherical grain where heat conservation expressed in both solid and liquid parts. Stefan condition of solid front advancement is imposed on the grain surface and curvature undercooling (Gibbs-Thomson relation) is also introduced as interface condition.

In this research works, we treat a phase change coupling energy transfer and mass transformation between different phases. From one side, the use of the developed numerical approach allows to predict the kinetic of crystal polymorphism of solid material undergoing thermal process like cold moulding, tempering and seeding, and further, derive relationships that can aid in process design. On the other side, the undercooling caused by grain curvature are analyzed at micro scale to be taken into account through a new coupling model describing the interaction between macro and micro effects. Note that developed approach contributes an applicable predictive tool to many industrial applications, like for example, polymer processing, cement manufacture, food processing (chocolate) and pharmaceutical industries.

**Patent:** Y. Safa, *Une turbine éolienne bionique plus légère que l'air.*, Bern Switzerland. PAdmin Cr/00168/17.

## 1.8 Powder Coating: A Post Processing Tool to Analyze Powder Coating Thickness Data

**Powder coating is an environmentally friendly alternative to other methods for providing surface finishes. A big challenge in the field has been the non-invasive assessment of the quality of a coating. To address this issue the Coatmaster 3D technology [1], based on advanced thermal optics, was used to gather thickness information from coated substrates. Subsequently a post processing tool was developed for the assessment of the data in terms of the coating performance parameters derived also in the scope of the project.**

Contributors: Bercan Siyahhan, Marlon Boldrini, Gernot Boiger  
 Partners: Winterthur Instruments, Wagner International AG  
 Funding: Innosuisse  
 Duration: 2016–2019

A post processing tool was developed using Python and its TkInter GUI package. It also links to Paraview for data visualization functionalities. The tool comprises mainly of data filtering and statistical analysis frameworks. The data filtering procedures include: (i) elimination of geometric and measured value outliers, (ii) exclusion of specified geometric regions, and (iii) automatic noise elimination with a median filter-based masking procedure. The statistical operations directly yield the performance parameters of coating processes. The first performance parameter is the average coating thickness (ACT):

$$ACT = \frac{1}{N} \sum_{i=1}^N D_i$$

The ACT is a direct indicator of the coating efficiency, as between two different coating procedures with the same amount of powder being used, the one with the higher ACT will have deposited a higher portion of the powder, hence a higher efficiency. The second performance parameter is a measure of how inhomogeneous (In) the coating on a substrate is:

$$In = \frac{1}{N} \sum_{i=1}^N (D_i - D_{max})^2 \cdot N_{max} \cdot D_{max}$$

The In is basically a weighted, normalized standard deviation of the thickness from the most frequently measured value on its discrete distribution graph illustrated in Fig. 1.

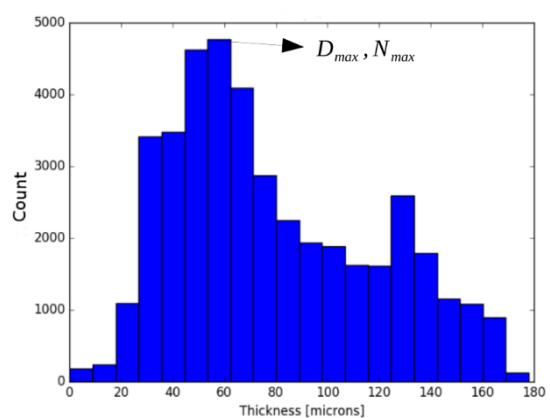

Fig. 1: Thickness measurement data as a discrete distribution.

A homogeneous coating is desired in most cases in practice hence a procedure with a lower In will be favoured.

The tool has the capability to apply the outlined procedures to large sets of data automatically, laying the groundwork for parameter optimization of coating processes and numerical simulation [2] comparisons.

### Literature:

[1] A. Bariska, N. Reinke, Berührungslose thermische Schichtprüfung, ZHAW Winterthur, Switzerland. Swiss Engineering STZ, 2011.

[2] G. Boiger, Euler-Lagrangian Model of Particle Motion and Deposition Effects in Electro-Static Fields Based on OpenFoam, The International Journal of Multiphysics, 2016.

## 1.9 Test Bench for Contactless Welding of Plastic Samples

The infra-red welding process is a widely used method in technology for joining plastic pipes. The components to be joined are placed at a certain distance from the heating mirror, heated and joined with a predefined force. Due to the distance between the heating mirror and the tube ends, the components are primarily heated by heat radiation. This leads to a concave melt front, which can negatively influence the quality of the weld seam. On a test bench, the best heating system solution should be evaluated with regard to optimum weld seam quality.

Contributors: N. Jenal, M. Gorbar, S. Spirig, T. Hocker, C. Brändli

Partners: Institute of Materials and Process Engineering (IMPE), Georg Fischer Piping Systems

Funding: Innosuisse

Duration: 2018–2021

In the infrared welding process, the pipes to be joined are placed at a certain distance from the heating mirror. The distance between the heating mirror and the pipe ensures that the amount of impurities entering the weld seam can be kept to a minimum. This process is therefore frequently used in technical areas where a high degree of purity is required. It is used, for example, for the production of pipelines in clean rooms. The ends are primarily melted by heat radiation, see Fig. 1. This heating process leads to a concave shape of the melt front which can negatively influence the quality of the weld seam.

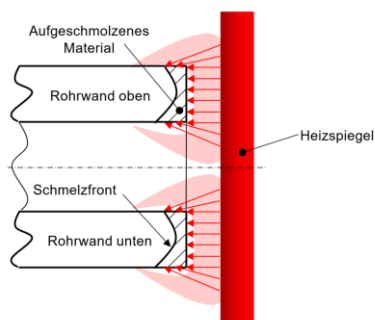

Fig. 1: Schematic representation of the infrared welding process.

A test bench should be used, among other things, to evaluate which influences the dynamic of the heating process and the joining force have on the weld seam quality. So that different heating element thicknesses can be mounted on the test bench, the elements are attached to the swivel arm via a clamping device, see Fig. 2. The heating element can be precisely positioned manually in vertical and horizontal direction with the use of wing nuts. The joining force is applied via a compression spring.

The spring force can be variably adjusted via a hexagon nut. An additional built-in force sensor is used to check the spring force.

Furthermore, the test bench is to be used for validation as soon as an optimum for the sample/heating element distance has been found by means of CFD tests.

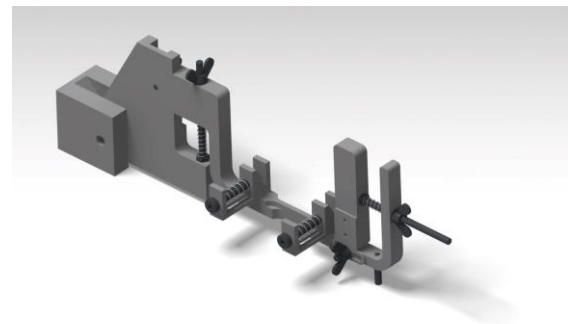

Fig. 2: Swivel arm for mounting various heating systems including mechanisms for fine adjustment.

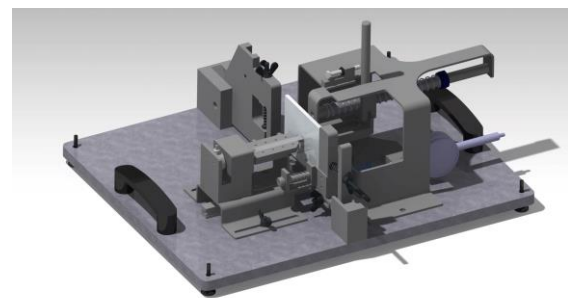

Fig. 3: Current design of the test bench for contactless welding of plastic samples.

### 1.10 Dynamic Delamination in Morphing Blades and Wings

A numerical framework for the study of delamination in morphing composite blades and wings is introduced using eXtended Finite Element Method (XFEM), and nonlocal continuum mechanics (peridynamics (PD)) to study fracture in the stiffener used in conjunction with the blade. As for the composite morphing blade, cohesive elements are used to represent the interlaminar weak zone and delamination has been studied under dynamic pulse loads. Intraply damage is studied using peridynamics with capability to address the problem adequately for the necessary level of sophistication. Through the use of fracture energy alone the nonlocal model is capable of capturing intra- and interlaminar fractures. The proposed framework can thus have a major impact in design applications where dynamic pulse and impact loads of all natures (accidental, service, etc.) are to be considered and may therefore be utilised in design of lightweight morphing blades and wings.

Contributors: A. S. Fallah, M. Ghajari, Y. Safa  
 Funding: Swiss National Science Foundation  
 Duration: 2018

Advances in structural aerodynamics have given rise to constant evolution in novel blade designs of improved airfoil cross sections and wings with continuous shape morphing. This allows these flexible structures to adapt continuously their shapes with respect to aerodynamic conditions and applied loads. Under the action of dynamic pulse loads there could be fracture in the stiffener (Fig. 1)

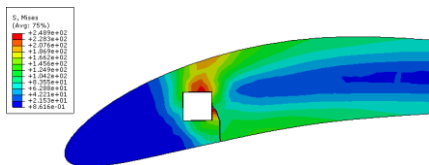

Fig. 1: XFEM crack in the stiffener and its propagation towards the boundaries.

In morphing blade, depending on the regime of pulse loading (impulsive, dynamic, quasi-static), the pattern of fracture would be different. Interlaminar fracture may be accurately captured using cohesive elements (Fig. 2 and 3), but for intra-ply fracture peridynamics was used (Fig. 4)

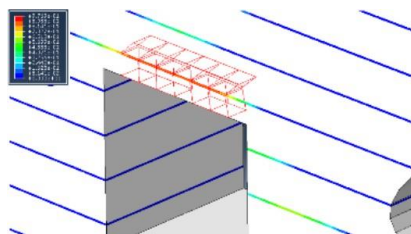

Fig. 2: Excessive shear distortion.

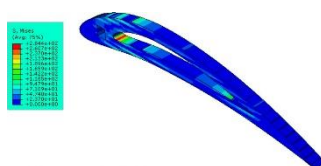

Fig. 3: Stress distribution and mismatch.

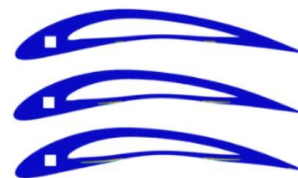

Fig. 4: Simulation under impulsive loading fracture using PD.

The differences and similarities between delamination patterns for impulsive, dynamic, and quasi-static loadings are appreciated with detailed analyses of delamination patterns. It is anticipated that in the case of an impulse higher modes of vibration are triggered and the delamination occurs throughout the blade in several locations simultaneously or sequentially, however, for quasi-static loading the pattern of fracture is more as propagation from a single location till complete separation and subsequent cracks are mostly geometric i.e. due to large deformations and change of initial configuration. For dynamic pulse a mixture of both phenomena may be encountered depending on whether the pulse is closer to an impulse or to a quasi-static load. It is shown the proposed framework is capable of capturing all major features of dynamic delamination in composite morphing blades through an accurate and consistent computational modelling scheme.

*Paper:*

A. Fallah, M. Ghajari, Y. Safa, *A computational framework for the study of dynamic delamination in morphing composite blades and wings*, Submitted to Journal Engineering Structures.



## 1.11 Spectral Composition of the Faraday instability in Small Vessels

The agitation of liquids inside vessels is a source of problems for biological or pharmaceutical liquid solutions. One important aspect to understand the agitation of aqueous solutions is the stability threshold above which the free surface shows normal modes. The parametric instability under vertical vibration has been extensively studied theoretically and experimentally.

Contributors: A. Zubiaga, G. Boiger, D. Brunner, F. Sager, M. Clemens, E. Koepf  
 Partners: F. Hoffmann-La Roche Ltd. Basel  
 Funding: F. Hoffmann-La Roche Ltd. Basel  
 Duration: 2018–2019

Mechanical stress conditions, such as agitation during shipping, can result in denaturation and aggregation of biomolecules, thereby affecting the stability of the products profoundly. The transportation degradation is linked to the shear stress induced by the agitated fluid.

Exposed to vertical vibrations, liquids are prone to show Faraday instabilities when the acceleration grows above certain threshold value. These modes are stationary and can grow large inducing a high shear stress on the dissolved product. The vessel shape, its dimensions and the fluid characteristics (mass density, viscosity and surface tension) influence the formation of instabilities. The parametric instability under vertical vibration has been studied thoroughly by Kumar & Tuckerman [1] using a Floquet analysis for viscous fluids.

For this work, both theoretical and experimental studies for small vessels have been performed [2]. The mode components of the Faraday instability have been calculated with a Floquet analysis in a wide frequency range, ranging from 5 Hz to 150 Hz. The calculated Faraday instability threshold has then been validated experimentally by measuring water in small vials under vertical vibrations (Fig. 1). A qualitative agreement with the theory is observed, and the disagreement in the position of the stability tongues can be well explained by the non-linear viscosity effects exerted by the container walls.

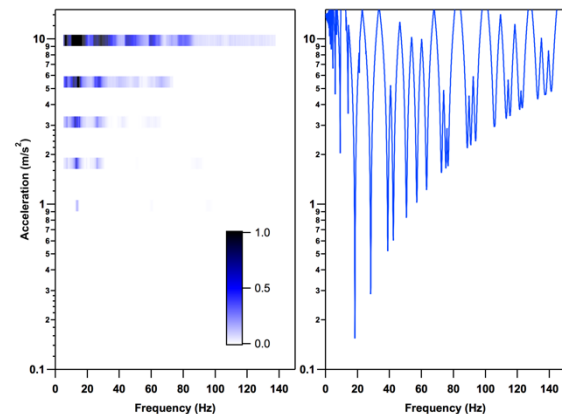

Fig. 1: The acceleration plotted versus frequency in the experiments (left panel) and in the stability analysis (right panel).

The lower  $k$ -momentum cut-off has a protective effect on the liquid against low-frequency instabilities. At frequencies larger than 20 Hz, the instability threshold increases steeply due to the intrinsic response of the liquid to high frequencies. The existence of a low stability region between 10 and 70 Hz has been confirmed by the experiments. Future studies will study the influence of fluid characteristics in the position of the stability threshold, as well as the increase on the shear stress caused by the Faraday instability.

### Literature:

- [1] Kumar K, Tuckerman LS. Parametric instability of the interface between two fluids. *J Fluid Mech.*, 1994, 279, 49–68.
- [2] A. Zubiaga, D. Brunner, F. Sager, M. Clemens, E. Koepf, G. Boiger. Faraday instability in small vessels under vertical vibration. *Int. J. Multiph.*, 2019, submitted.

## 1.12 PVT-Hybrid Collectors: Heat and Electricity from the Sun

**The coupling of photovoltaics and solar thermal energy with PVT hybrid modules promises an additional benefit compared to the conventional use of solar energy. Both in the construction of these modules and in system integration, the ICP makes an important contribution with advanced computer simulations.**

Contributors: T. Frei, D. Schaltegger, A. Witzig

Partners: Ponzio Solar SA, Institut für Energietechnik und Fluidengineering (IEFE)

Funding: Innosuisse

Duration: 2017–2019

The roof area for the use of solar energy is becoming scarce. This is a great opportunity for PVT hybrid collectors: solar electricity is produced and energy in the form of heat is harvested simultaneously on every square metre.

PVT hybrid collectors have different areas of application:

- When the heat is used for domestic hot water, the temperature level is kept high. The heat is transferred to the hot water storage tank via a heat exchanger. Compared to other PVT systems, this configuration promises a good compromise between efficiency and energy costs.
- Combination with heat pump and ground-source loops or ice storage: in this situation, a great deal of energy can be harvested. Heat utilisation still brings high yields not only in direct sunlight, but also in diffuse light and high outside temperatures.
- Combination with a heat pump to replace the ground connection: this configuration promises a cost-effective solution, since expensive energy storage in the ground is no longer necessary [2]. The PVT hybrid collector is operated as a heat exchanger against the outside air. A careful design on the basis of simulations is a prerequisite, however, since the required heat output cannot be obtained in the event of incorrect dimensioning.

The modelling competences at ICP are used to support system optimization and to extend the simulation models. On the one hand, the

commercially available software Polysun [3], and on the other, new computer models are developed and verified by measurements [4, 5].

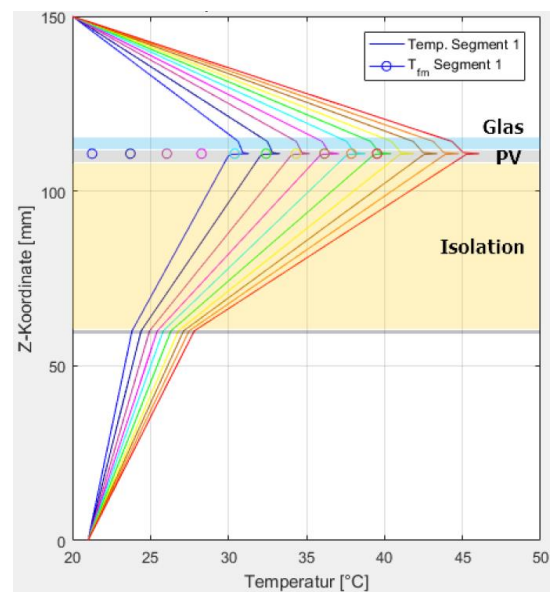

Illustration: Simulation of the PVT hybrid collector. Temperature curve at 10 points along the meandering heat exchanger pipe system.

### References:

- 2] Ch. Schmidt et. al. (Fraunhofer ISE): PVT collectors integrated into the heat pump heating system on the source side. Solar thermal symposium, Bad Staffelstein, June 2018.
- 3] [www.polysunsoftware.com](http://www.polysunsoftware.com)
- 4] T. Frei: Fabrication and thermal simulation of novel hybrid collector. Student work ICP-ZHAW, February 2017.
- 5] T. Frei: Simulation of a hybrid collector in transient operation. Student Work ICP-ZHAW, September 2017.

## 2 Electrochemical Cells and Microstructures

Fuel cells are a prime example of electrochemical cells. They convert fuels such as hydrogen, natural gas or methanol into electrical energy and heat. Fuel cells can be used as a battery replacement in portable electronic devices, for combined production of heat and electricity in households and as electricity source in vehicles. Due to their flat design, fuel cells are easily scalable by connecting them in series to form stacks. Electrical efficiencies over 60% are feasible which is much higher compared to other decentralized electricity generation technologies. Redox flow batteries are considered as a promising energy storage technology. These batteries are highly efficient and they provide an energy storage solution for fluctuating energy from wind mills and photovoltaic cells.

The ICP supports the progress in the research and development of electrochemical cells by multiphysics computer models. In general, modeling helps to better understand the coupling of chemical, thermal, electrical, mechanical and fluidic processes with the goal to detect weaknesses of the system and provide design improvements. Often these models rely on detailed information about the microstructures of the investigated materials. Hence the characterization of gas diffusion layers and electrolyte micro-structures in 2D and 3D is an integral part of our modeling efforts.

In addition to fuel cells, we also do research on novel hydrogen production techniques. For example, we model photo-electro-chemical cells (PECs) which use solar energy to split water and thus produce hydrogen fuel. Most research projects are conducted in collaboration with our strategic partners Hexis AG in Winterthur (SOFC), Paul Scherrer Institut in Villigen (PEFC), EPFL (hydrogen generation) in Lausanne and Universität Ulm (virtual microstructures).

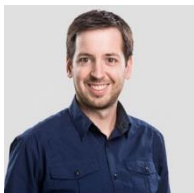

David Bernhardsgrütter



Robert Herrendörfer



Gaël Mourouga



Jürgen Schumacher



Jakub Włodarczyk

## 2.1 Simulating the Energy Yield of Next Generation Photovoltaics

**Emerging 3rd generation photovoltaic technologies are characterized at standard test conditions in laboratory, yet it is uncertain how they perform in real outdoor installations. We have developed a model to simulate the energy yield of PV modules considering geographical position, local weather and characteristics of the device. We use the tool to analyze the performance loss of monolithically connected tandem solar cells caused by red/blue changes of the solar spectrum. For the promising silicon heterojunction perovskite tandem cell, we obtain a mismatch loss of 1.27% on the integrated annual module power.**

Contributors: D. Bernhardsgrütter, M. Schmid  
 Partners: EPFL-LPI, EPFL PV-Lab, EMPA-TFPV  
 Funding: SNF  
 Duration: 2015–2018

We have developed a tool to simulate the energy yield of 3rd generation PV technologies including the promising silicon heterojunction perovskite tandem cell (SHJ-PSC). It allows us to assess the performance loss of tandem solar cells operating at real outdoor conditions compared to standard test conditions (STC), for which they are optimized. Additionally, the simulated power output provides data required for the analysis of the impact of novel PV technologies on the grid.

The model considers the geographical position, local weather, orientation and characteristics of the device, i.e. external quantum efficiency (EQE), current-voltage curve (IV) and temperature coefficients. To estimate the energy production of outdoor installations, synthetic clear-sky spectra are generated considering the atmospheric absorption and the red/blue changes of the spectrum. Then weather data consisting of integrated irradiance, temperature, wind, and pressure are used to rescale the spectra to the measured irradiance and to estimate the module temperature. EQE and IV data together with temperature coefficients are then used to predict the module power.

To validate the model, we have compared the predictions of our forecasting tool with simulation results generated with the commercial software PVsyst. The comparison has been conducted for a generic module and weather data of the year 2017, resulting in annual deviations of less than 5%, cf. Fig. 1.

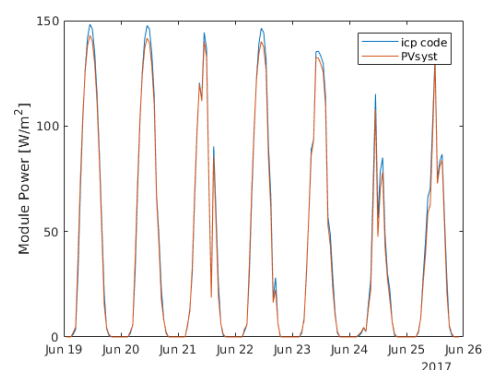

Fig. 1: Simulated power output of the module TSM-290DD05A.08(II) calculated with our model and with PVsyst.

We applied the validated model to quantify the current mismatch losses of monolithic two-terminal (2T) tandems caused by blue/red changes of the solar spectrum. We used the simulation software SETFOS to generate the EQE and IV of a power-matched SHJ-PSC. The mismatch losses have been estimated by comparing the energy yield of the 2T tandem with the sum of the performances of each sub-cell operating independently. We obtained a mismatch loss of 1.27% on the integrated annual module power.

No mismatch losses arise for mechanically stacked four-terminal (4T) tandems, but an additional transparent electrode is necessary leading to increased parasitic optical losses. We have thus calculated an upper limit for these absorption losses for the 4T tandem to be more efficient than its 2T counterpart.

## 2.2 Analyzing the Dynamic Response of Perovskite Solar Cells

Within less than a decade since their advent, perovskite solar cells (PSCs) have reached efficiencies on a par with silicon-based cells. Numerical simulations provide insight into the physical processes within these novel cells, facilitating further optimization of the technology. When PSCs are excited by intensity-modulated light with varying frequency, they show a response at low frequency which is characteristic for these devices. We use a drift-diffusion model to link this unique feature to mobile ions within the cell.

Contributors: D. Bernhardsgrütter, M. Schmid  
Partners: EPFL-LPI, EPFL PV-Lab, EMPA-TFPV  
Funding: SNF  
Duration: 2015–2018

Perovskite solar cells have attracted tremendous interest within the photovoltaic community over the last decade. The technology is regarded as a promising candidate to compete with silicon solar cells in the near future. The excellent optical and electrical properties of perovskite materials have boosted the efficiencies above 20% within less than 10 years of research. No other technology has achieved comparable results in such a short stretch and perovskite has the bonus of being a potential low-cost technology through low-temperature solution processing. Furthermore, their absorption properties make them an ideal candidate as top cell in combination with bottom silicon cells to form even more efficient tandem solar cells.

Intensity-modulated photocurrent spectroscopy (IMPS) and intensity-modulated photovoltage spectroscopy (IMVS) are important characterization techniques for solar cells. The cells are exposed to sinusoidally modulated light, while either the current (IMPS) or voltage (IMVS) response is measured. These techniques are applied to probe transport and recombination of charges within the cell. By measuring the response for a wide range of frequencies, varied processes at different time-scales are revealed.

Perovskite solar cells admit a distinct response at low frequency ( $< 10$  Hz). We use numerical simulations to test the hypothesis, that mobile ions are responsible for this feature. Our model comprises one-dimensional drift-diffusion equations coupled with ion transport. Two complementary methods are used to compute the small signal response. The sinusoidal steady-state analysis (S3A) is based on linearization of the model equations around the stationary operating point. Typical results of the S3A-method are depicted in Figure 1.a, b). In contrast, Fourier decomposition (FD) entails the computation of the Fourier transform of the transient cell response to a light intensity step, cf. Figure 1.c). While the S3A-method is more efficient and accurate, the FD-method provides additional interpretation of IMPS and IMVS results by relating the time and frequency domains.

Our results indicate that the low-frequency response of PSCs is explicable by ion migration. As the ions are assumed to have low mobility, they respond to the excitation on different time-scales as electrons and holes. Simulated IMPS and IMVS responses therefore admit two separate time constants, cf. Figure 1.b). The origin of the high frequency response lies in the transport and recombination of electronic charges, while the low frequency response is associated with mobile ions.

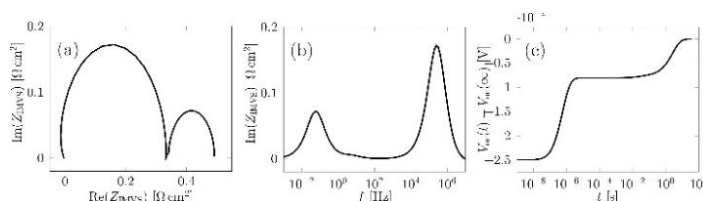



Fig. 1: Simulated IMVS response of a perovskite solar cell. Part a) shows the Nyquist plot and subfigure b) the imaginary part of the IMVS transfer function. The simulated photovoltage of a PSC excited by a small light intensity step is shown in subfigure c).

## 2.3 Advanced Characterization of Fuel Cell Stacks for Automotive Applications (ACTIF)

The project ACTIF aims at optimized operational strategies for fuel cell systems regarding the three main aspects efficiency, life-time and costs on the stack level. This will be enabled by enhanced understanding of fuel cell stacks on the basis of advanced time-resolved characterization techniques and mathematical modeling. 

Contributors: J. O. Schumacher, R. Herrendörfer  
 Partners: GreenGT  
 Funding: Swiss Federal Office of Energy SFOE  
 Duration: 2018–2021

During the initial phase of this project (October 2018 - December 2018), we have developed a time-dependent single-cell polymer electrolyte fuel cell (PEFC) model. On the basis of the fully parameterized, one-dimensional and steady-state two-phase model previously developed at ICP, we additionally account for the time-dependency in the governing equations for electrons, protons, heat, dissolved water, gas and liquid water. Implementation in COMSOL Multiphysics allows for accurate spatio-temporal numerical resolution and flexible model setups.

To test our new implementations, we have conducted time-dependent numerical experiments. In so-called jump experiments, during which boundary conditions are changed abruptly, we analysed the duration of the transients of each governing process. In agreement with theoretical values, the characteristic time constant is the longest for membrane hydration and the shortest for electrical double layer charging and discharging. We showed that the membrane hydration is therefore responsible for the hysteresis effect observed in cyclic voltammetry experiments (Figure 1). Furthermore, we proved the numerical stability of our approach by showing that the solution algorithm converged with increasing spatiotemporal resolution.

The next steps of this project are the extension of this time-dependent model on the stack level, model order reduction and implementation of fuel cell degradation mechanisms. We plan to apply the model to simulate the dynamic response of a fuel cell system of the Swiss company GreenGT and collaborate with the German partners Fraunhofer ISE and DLR. This collaboration targets the validation of our model using experimental measurement data.

This will be essential for the model-based characterization and optimization of fuel cells systems with respect to performance and durability.

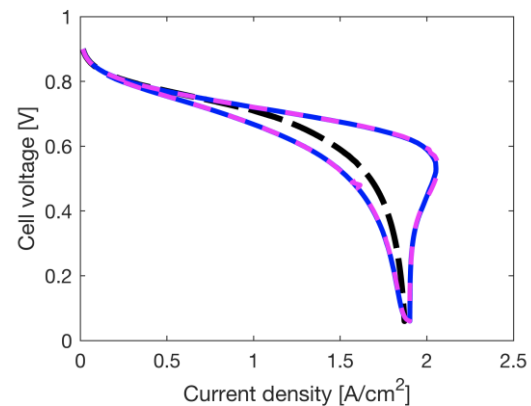

Figure 1: The figure shows the fuel cell polarization curve resulting from the simulation of a cyclic voltammetry experiment. The magenta line represents the solution obtained only with the accumulation term in the conservation equation of dissolved water (i.e., the membrane water content). The steady-water solution (black curve) is plotted for comparison.

## 2.4 Experimental Parameter Uncertainty in Polymer Exchange Membrane Fuel Cell Modeling

**This project aims at determining the transport parameters of polymer exchange membrane fuel cells (PEMFC). The first part of this work addresses the scatter in material parameterization and its impact on the simulated polarization curves. The second part analyses the sensitivity of the model output to uncertainties by introducing the concept of condition number to fuel cell modeling.**

Contributors: R. Vetter, R. Herrendörfer, J. O. Schumacher

Partners: Swiss energy competence center (SCCER): Efficient technologies and systems for mobility (SCCER Mobility)

Funding: Innosuisse

Duration: 2014–2020

The predictive power of PEMFC models has suffered from significant uncertainty in the parameterization of material properties. In this project the most critical transport parameters were determined for which a more accurate experimental characterization is required to enable reliable fuel cell performance prediction.

In the first part, a comprehensive set of material parameterizations from the literature was incorporated into the recently developed macro-homogeneous two-phase membrane-electrode assembly model at ICP [1]. This numerical model demonstrated the large spread in performance prediction resulting from published experimental data on material properties. Different published membrane transport properties induced the largest spread in the fuel cell performance curve: the diffusivity of dissolved water, the protonic conductivity and the electro-osmotic drag coefficient [2].

To analyze the sensitivity of the model output to uncertainties in the model input in a robust way, the second part conducted extensive forward uncertainty propagation analyses for 26 input parameters (operating conditions and material parameters) and 12 output parameters (characteristics of the polarization curve and fuel cell state) [3]. By introducing the concept of condition numbers to fuel cell modeling, the propagation of uncertainty through the model is measured explicitly. Besides a local sensitivity analysis, a global sensitivity analysis was conducted that covers a broad range of operating conditions and material properties.

Among the most critical model parameters are the membrane transport properties (Figure 1): membrane hydration isotherm, the electro-osmotic drag coefficient, the membrane thickness and the diffusivity of dissolved water. As shown in first part,

these parameters suffer from the largest scatter in available experimental data. This calls for a better characterization of the membrane properties.

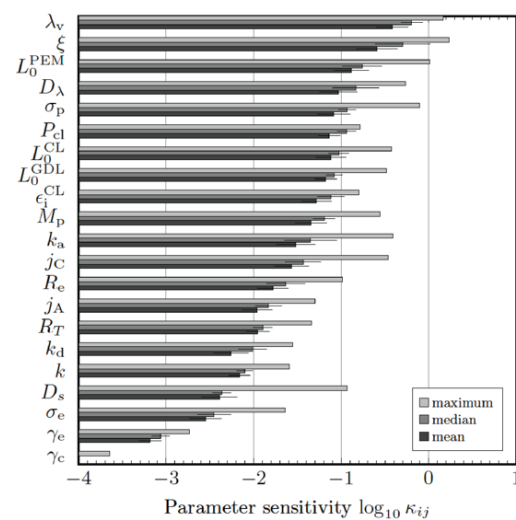

Figure 1: Global model sensitivity to parameter uncertainty. Material parameterizations are sorted by significance in decreasing order.

### Literature:

- [1] R. Vetter and Jürgen O. Schumacher, *Computer Physics Communication*, 234, 223–234, 2019
- [2] R. Vetter and Jürgen O. Schumacher, 2019 arXiv:1811.10091
- [3] R. Vetter and Jürgen O. Schumacher, 2019 arXiv:1811.10093

## 2.5 Modelling and Simulation of an Organic Redox Flow Battery Cell

Organic redox flow batteries show promises as a low-cost, sustainable energy storage device. It is still a very young technology, and a lot of work is required in optimizing materials and components. The aim of this work is to provide a macrohomogeneous model of the organic cells, in order to estimate the best compromise between performance and lifetime, and ultimately provide insights on various parameters of the cells. It is part of the project FlowCamp, a research and training project funded by the European Union's Marie-Sklodowska-Curie programme. FlowCamp involves 11 partner organisations from 8 different countries. Research in FlowCamp aims to improve materials for high-performance, low-cost next-generation redox-flow batteries.

Contributors: G. Mourouga, J. O. Schumacher

Partners: ETH Zürich, Hungarian Academy of Science, Univ. Grenoble-Alpes, JenaBatteries

Funding: European Commission, Horizon 2020, Marie Skłodowska-Curie Training Networks

Duration: 2018–2021

There are two organic chemistries under study in the FlowCamp project: all-quinone and all-polymer. The former consists of quinones – cheap, natural charge carriers, encountered in photosynthesis processes for example – dissolved in an aqueous sulfuric acid electrolyte. The latter consists of synthesized long-chain polymers dissolved in sodium chloride. While the equations of the models are valid for both chemistries, our efforts have for now focused on the all-quinone chemistry, because of a greater amount of data available.

The redox active molecules for this system are 1,2-dihydrobenzoquinone-3,5-disulfonic acid on the positive side and anthraquinone-2-disulfonic acid on the negative side (left and right tank respectively, see figure below)

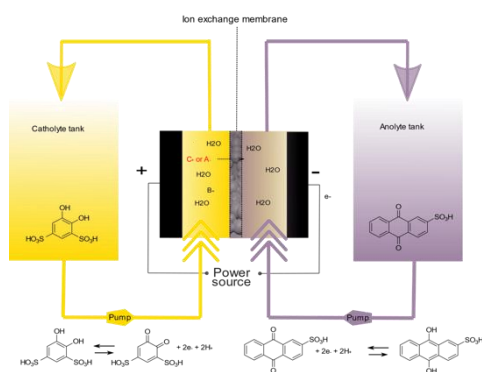
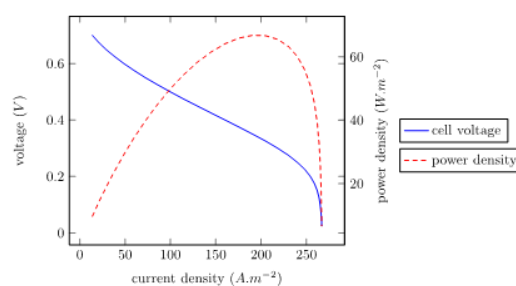

Figure 2. Illustration of an all-quinone organic redox flow cell.

These molecules yield a fast proton-coupled electron transfer process, and the absence of precious metal catalysts make the all-quinone chemistry an interesting candidate for green, low-cost energy storage [1].

The downside is that this chemistry yields a relatively low energy density compared to other chemistries, and solutions to overcome this may result in an increased crossover of the benzoquinones to the negative electrode, which in turn reduces the expected lifetime of the battery [1].



The aim of our work in the FlowCamp project is to provide a reliable model of the cells, which would allow us to tune properties such as electrolyte composition and viscosity, membrane properties and organic cell architecture [2].

The 1D macrohomogenous model of the cell includes charge and mass transport phenomena in the electrodes and the membrane. We are working on a multicomponent diffusion model, in order to better model the transport phenomena in the ion-exchange membranes, which are a critical component of these cells.

### Literature:

[1] B. Yang, L. Hooper-Burkhardt et al., *Journal of The Electrochemical Society*, vol. 161, no. 9, 2014.

[2] <https://www.flowcamp-project.eu/>



## 2.6 Modeling and Simulation of a Hydrogen-Bromine Redox Flow Battery Cell

The main issue of emerging technologies in renewable energy storage is their cost. It can be mitigated by utilizing cheap and abundant reactants such as hydrogen and bromine. This study describes a macrohomogeneous modeling approach to the hydrogen-bromine redox flow battery system as well as case studies to better understand the impact of key operating parameters on the overall cell performance. It is part of the FlowCamp project [1], a research and training project funded by the European Union's Maria Skłodowska-Curie program. FlowCamp involves 11 partner organizations from 8 different countries. Research in FlowCamp aims to improve materials for high-performance, low-cost next-generation redox-flow batteries.

Contributors: J. Włodarczyk, J. O. Schumacher

Partners: Elestor B.V., Fraunhofer Institute for Chemical Technology, University of Stuttgart

Funding: European Commission, Horizon 2020, Maria Skłodowska-Curie Training Networks

Duration: 2018–2021

One of the flow battery systems which utilizes abundantly available chemicals for electrolytes, characterized by high power density, is the hydrogen-bromine flow battery (HBRFB).

A typical setup of a HBRFB system consists of an electrolyte storage vessel and a pressurized hydrogen gas vessel, electrolyte circulation pump, and a cell stack, which is composed of current collectors, bipolar plates, porous electrodes (carbonaceous materials for the Br<sub>2</sub> side and platinum alloys for the H<sub>2</sub> side), and an ion-selective membrane.

On discharge, at the negative electrode, dissolved hydrogen gas diffuses to the catalyst surface and is oxidized to protons on discharge. At the same time, at the positive electrode, dissolved bromine gas diffuses to the catalyst surface and is reduced to bromide anions. In the processes of charging, both reactions are reversed with a relatively high efficiency of up to 80% [1] due to facile electrokinetics.

In the activities encompassed by the FlowCamp project we are developing a continuum-scale mathematical model of a single-cell hydrogen-bromine flow battery (HBFB). It comprises of the most relevant transport through-plane processes and electrochemical phenomena for the operation of the HBFB, that is, transport of charge, water, hydrogen, protons, bromine and bromide.

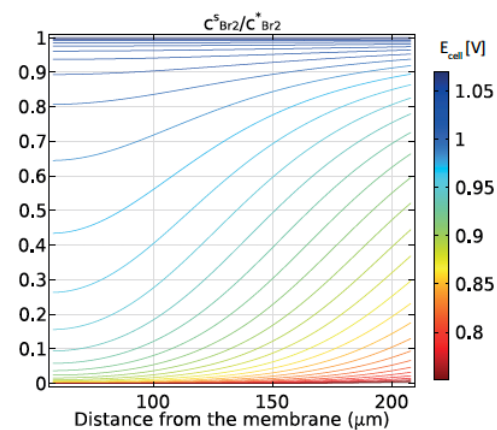

Fig. 1: Bromine surface concentration to bromine bulk concentration ratio distribution in the carbon felt electrode on discharge.

Furthermore, the model is enriched with supplementary phenomena such as: Nernstian losses due to reactant local surface concentration variations, Donnan potential on the HBr/Br<sub>2</sub> solution-membrane interface, and gas adsorption in the ionomer on the gaseous hydrogen side according to Henry's law.

The FlowCamp project promotes a strong collaboration amid the participants and creates a bond between empirical and modeling studies. This approach opens a spectrum of possibilities for experimental validation of the computer simulations. These serve to develop guidelines to design recommendations implemented by experimentalists.

### References:

[1] FlowCamp project website available at: [www.flowcamp-project.eu](http://www.flowcamp-project.eu)

## 2.7 Microstructure Evolution upon High Temperature Corrosion of Metallic Interconnectors (MIC) for Solid Oxide Fuel Cells (SOFC)

**Oxidation of metallic interconnectors (MIC) is a major source for performance loss, which limits the lifetime of SOFCs. Oxidation rate and associated contact resistance can be influenced by suitable choice of interconnector materials and coatings. In this project the microstructure evolution of oxide scales is investigated for two ferritic steels with and without coatings. A detailed characterization of the microstructure represents the basis for a fundamental understanding of the underlying mechanism, which is necessary for purposeful materials improvement.**

Contributors: L. Holzer, L. Keller, T. Hocker, D. Burnat, A. Heel, F. Fleischauer, J. Grolig, A. Mai

Partners: Hexis, ScopeM/ETHZ

Funding: BfE

Duration: 2015–2018

High temperature oxidation was investigated for two ferritic steels (Crofer22APU and 1.4509). Samples with different coatings (Co, MnCoFe) were oxidized at 850°C in air. The microstructure evolution was characterized by time-lapse microscopy at distinct time steps up to 5400 hours. Microstructure characterization at ETHZ (ScopeM), involved broad ion beam (BIB), SEM- and (S)TEM-EDX.

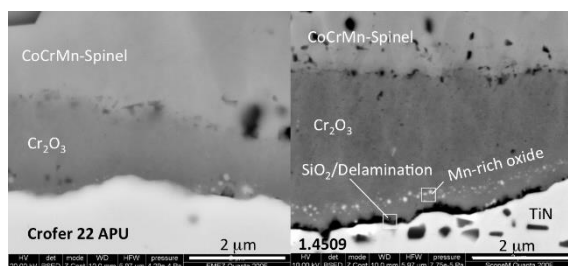

Fig. 1: Example of scale microstructures after oxidation for 500 hours at 850°C in air. Left: Crofer 22 APU with Co-coating, right: 1.4509 with Co-coating. Note difference of MIC-scale interface.

On both ferritic samples without coating a duplex scale is formed consisting of  $\text{Cr}_2\text{O}_3$  and MnCr-spinel on top. For Crofer the MIC-scale interface is perfect. In contrast, 1.4509 shows high porosity and strong delamination at the MIC-scale interface. Subtle changes of the MIC composition induce significant differences in the microstructure. In particular, a slightly higher Si-content of 1.4509 leads to the formation of Si-oxide (ca. 10-20 nm needles) at the MIC-scale interface, which is responsible for the observed delamination. For 1.4509 with Spinel-coating, delamination can be suppressed at early oxidation stages. However, delamination is then even more complex at prolonged oxidation, where several delamination horizons can be detected at the MIC-scale interface and within the oxide layers. During the ongoing oxidation the composition of the spinel coating changes due to interdiffusion (i.e. enrichment with Cr, Mn). These compositional changes may lead to a drop of conductivity and to

an increase of the contact resistance. In order to compensate such negative interdiffusion-effects the coating thickness must be increased.

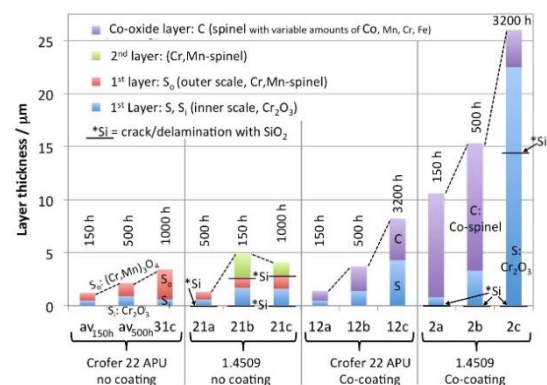

Fig. 2: Thickness of oxide layers for 4 materials.

The investigations also involved the quantification of oxidation rates and associated contact resistances. Delamination and spinel compositions are found to be more critical than the layer thicknesses. The results are promising in the sense that relatively cheap ferritic materials can be used in combination with coatings that are capable to suppress delamination and Cr-evaporation.

## 2.8 Model to Predict Degradation-Optimized Operation of High-Temperature Fuel Cell Stacks

Even though fuel cell stack developers have come a long way in reducing degradation that leads to power losses over time, a certain degree of ageing is considered to be unavoidable. It therefore makes sense to find out if a smart strategy to operate fuel cell stacks could be used to minimise power losses. Here we present first results showing how varying stack operation temperatures affect stack degradation.

Contributors: T. Hocker  
 Partners: Hexis AG, Winterthur, J. Grolig, F. Vandercruysse  
 Funding: Swiss Federal Office of Energy  
 Duration: 2018–2019

Assessing, understanding and reducing losses in fuel cell systems is a task that has been tackled both experimentally [1] and theoretically [2] over many years. Even though many advances have been made and fuel cell systems are starting to become commercially available, a certain degree of ageing is considered to be unavoidable. Since the ageing of fuel cells – such as batteries – depends on how they are operated, it would be highly desirable to employ smart operation strategies that help reducing power losses. In this project we analysed how changes in the stack operation temperatures affect stack degradation. For this, we employed a simple, yet powerful approach for expressing the internal resistance of a fuel cell stack repeat unit  $ASR_{RU}$  in  $m\Omega cm^2$  as a function of time and temperature. This approach is based on the complete differential of  $ASR_{RU}$  which in its integrated form is represented by

$$ASR_{RU}(t, T) = ASR_{RU}(t_0, T_0) + \int_{t_0}^t \left. \frac{\partial ASR_{RU}}{\partial t} \right|_T dt + \int_{T_0}^T \left. \frac{\partial ASR_{RU}}{\partial T} \right|_t dT$$

Based on Eq. 1, stack degradation data such as the synthetical data shown in Fig. 1 can be readily used to predict the time-dependent degradation for arbitrary T -profiles

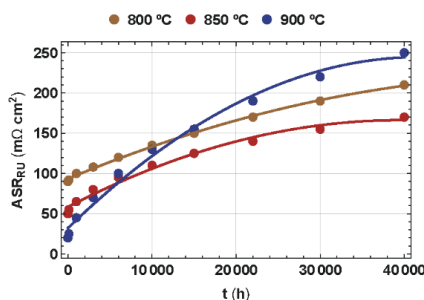

Fig 1: Synthetical data for the time- and temperature- dependent internal resistance of a fuel cell stack repeat unit.

The results of such an analysis is shown in Figs. 2 and 3. It turns out that increasing the stack temperature from 800 °C to 900 °C after 20'000 h decreases power losses compared with operation at constant temperatures of either 800 °C, or 900 °C.

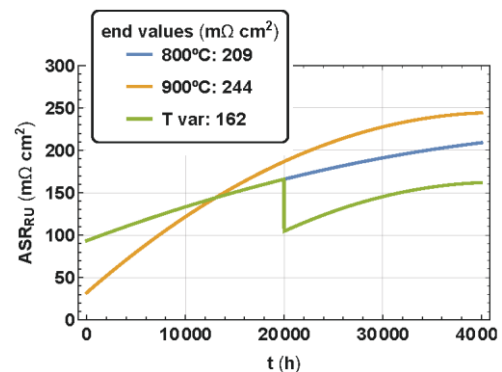

Fig 2: Evolution of the internal resistance of a fuel cell stack repeat unit for: T = 800°C T = 900°C and T increased from 800°C to 900°C after 20'000 h.

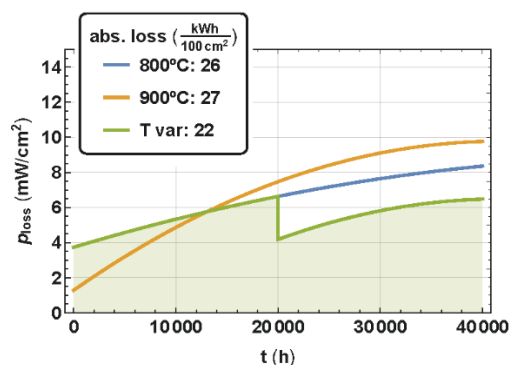

Fig 3: Power losses of a fuel cell stack repeat unit for the three different operation modes shown in Fig. 2.

### Literature:

- [1] A. Mai, B. Iwanschitz, J. A. Schuler, R. Denzler, V. Nerlich, A. Schuler, ECS Transactions, 57, pp. 73–80 (2013).
- [2] C. Meier, D. Meier, F. Vandercruysse, T. Hocker, *The International Journal of Multiphysics*, Vol. 12, 393–411 (2018).

# 3 Organic Electronics and Photovoltaics

Organic semiconductors have received great attention since 1987 when organic light-emitting devices were invented by leading scientists at Kodak USA. After 30 years of R&D and commercialization efforts world-wide, we are now witnessing a wide range of OLED displays in consumer products ranging from mobile phones to 77-inch TVs. The particular advantages of OLEDs is their thin construction, large viewing angle, color gamut and high energy conversion efficiency. OLEDs consist of a sequence of thin organic semiconductor layers placed in-between two metallic electrodes. Organic semiconductors have equally gained attention as strong light absorber and charge transport materials in organic solar cells, with which flexible PV modules can be built. In recent years, organic semiconductors have also been key to the ground-breaking hybrid organic-inorganic perovskite solar cell technology, which is the hottest emerging photovoltaics technology and shows great potential for LED applications, too. Further into the invisible range of electromagnetic waves, terahertz photonics is a growing technological field for non-invasive diagnostics applications. The ICP carries out R&D in the field of OLED, OPV, perovskite PV and non-linear optical crystals for tera-hertz photonics technology by employing multi-physics computer models and devising novel measurement systems. In the laboratory of the ICP, we fabricate OLEDs and novel solar cells on a small scale for R&D purposes and are setting up a terahertz photonics measurement system. We focus on device and material characterization methods by a combination of advanced measurement and simulation technology. This chapter gives an overview on ongoing R&D projects carried out in this interdisciplinary research field of the ICP.



Tobias Bach



Ennio Comi



Jonas Dunst



Mojca Jazbinsek



Christoph Kirsch

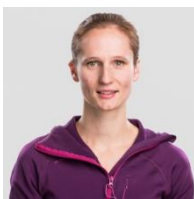

Evelyne Knapp



Vincent Michel



Martin Neukom



Kurt Pernstich



Uros Puc



Markus Regnat



Beat Ruhstaller



Andreas Schiller



Simon Züfle

### 3.1 From Lab to Fab: Upscaling of Perovskite Solar Cells

**Perovskite is a promising material for solar cells. Devices show record efficiencies of more than 20%, which is almost twice the conversion efficiency reached by organic solar cells. With the aid of numerical simulations and measurements the ICP aims at understanding these devices in more detail and helps improving a software tool to predict the performance of large-area perovskite cells.**

Contributors: E. Comi, E. Knapp, M. Neukom, B. Ruhstaller, A. Schiller  
 Partners: Empa, Fluxim AG  
 Funding: CTI  
 Duration: 2016–2019

The name of the Perolec project is composed of the two words "perovskite" and "OLEC" since the project aims at developing simulation and measurement tools for the perovskite solar cells and organic light-emitting electrochemical cells. It is assumed that the two types of devices have, in addition to electron and hole transport, ion transport in common. Ion transport is relatively slow in comparison with electron and hole transport. This behaviour requires an adaptation of the measurement system and simulation software. In previous years of the project the hardware was improved to fully characterize the devices. The numerical solver was complemented with the ionic transport equations to adequately describe the hysteresis in perovskite solar cells. These modifications were performed for small lab cells, sized a few mm<sup>2</sup>. Besides the development of measurement and simulation tools for small lab cells, we applied the software LAOSS by Fluxim AG for simulating large-area perovskite cells. To keep simulation times and load at a minimum a compact 1+2D approach is pursued. Instead of simulating a full 3D device, we take advantage of the characterization of the small cell and use this information to feed the large-area calculation as depicted in Fig 1. This configuration will account for the reduced conductivity of the transparent electrode and can include self-heating. We mimic small and large cells by covering the large cells with differently sized masks while shining light on them. The resulting current-voltage curves show an interesting shift of the open circuit voltage [1] which can partly be explained by

simulation. Currently, we are testing algorithms for fitting large-area current-voltage curves.

The collaboration with the ICP spin-off Fluxim allows for the implementation of the new tools into the simulation software Setfos and LAOSS and the integrated measurement solution Paios. All of them are commercially available and widely used by customers. The research partner EMPA fabricates OLECs and perovskite solar cells, which are then measured at ICP and Fluxim to test and validate the new tools. With the Perolec project ICP contributes to an emerging field in academic and industrial research.

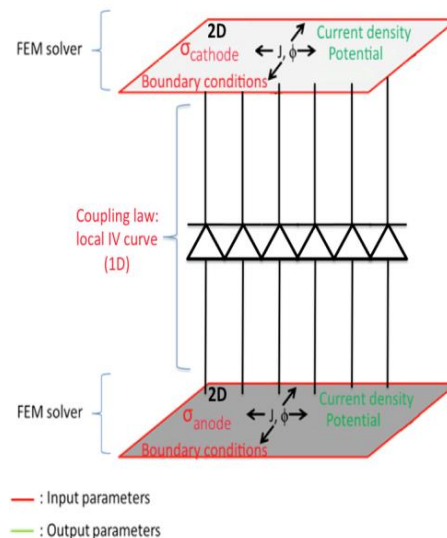

Fig. 1: Interplay of 1D model or measurement of lab cell and 2D model for electrodes.

#### Literature:

[1] Kiermasch et al., Effects of Masking on Open-Circuit Voltage and Fill Factor in Solar Cells, Joule (2018), <https://doi.org/10.1016/j.joule.2018.10.016>

### 3.2 Ultrabroadband THz Photonics Based on Organic Crystals

The goal of this project is to develop a new compact instrument for terahertz (THz) non-destructive material testing and characterization. The new system will allow for THz spectroscopic measurements, THz imaging and THz thickness measurements with an ultra- broadband spectral range beyond 15 THz, which is presently not available on the market.

Contributors: U. Puc, T. Bach, V. Michel, M. Jazbinsek  
Partners: Rainbow Photonics AG  
Funding: Innosuisse  
Duration: 2017–2019

Organic electro-optic crystals are very promising and efficient THz-wave generation materials. They allow for both very high THz electric fields, exceeding several GV/m using optical rectification of femtosecond laser pulses, as well as the possibility for extremely broad bandwidth extending well beyond 10 THz. However, the usual laboratory THz systems based on these crystals exploit very bulky and expensive Ti:sapphire femtosecond (fs) laser systems, which are not desired for industrial THz imaging and spectroscopy applications. We are therefore developing a compact THz time-domain spectroscopy and imaging system based on relatively low-cost and small-size femtosecond fiber lasers operating at telecommunication wave-lengths.

We characterized the refractive indices in the broad-band THz range of various state-of-the-art organic electro-optic crystals, DAST, DSTMS, OH1 and HMQ-TMS, which allowed us to evaluate theo-retically their best application ranges for ultra-broad THz-wave generation and coherent THz electric-field detection, depending on the available pump laser wavelength and the desired generated THz frequencies (see Fig. 1). For our pump fs laser source operating at the central frequency of 1560 nm, the best choice is DSTMS, which we also confirmed experimentally.

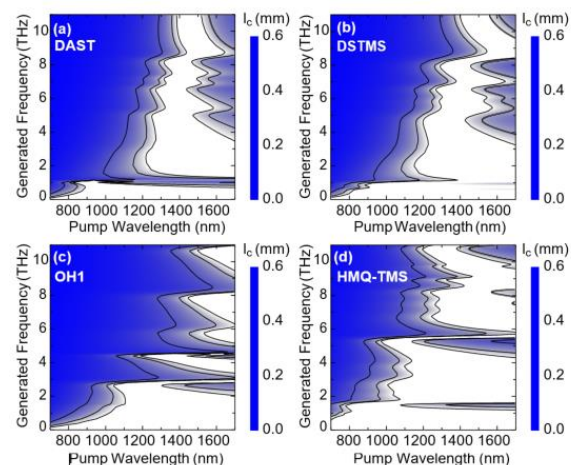

Fig 4: Coherence length  $l_c$  for THz-wave generation in (a) DAST, (b) DSTMS, (c) OH1 and (d) HMQ-TMS as a function of the pump optical wavelength and the generated THz frequency  $f$ . The white area coher represents ence lengths larger than 0.6 mm and therefore best for efficient THz-wave generation and/or detection.

We employ a very compact ( $19.5 \times 9.5 \times 7.5 \text{ cm}^3$ ) commercial fs laser from Menlo Systems with pulse length of 40 fs, 190 mW average power, 100 MHz repetition rate as pump beam. Figure 2 shows the acquired THz time-domain electric field and the corresponding power spectrum obtained in dry air atmosphere using DSTMS crystals for both THz-wave generation and detection. We achieve a very large frequency bandwidth extending beyond 15 THz, with a high dynamic range of up to 60 dB.

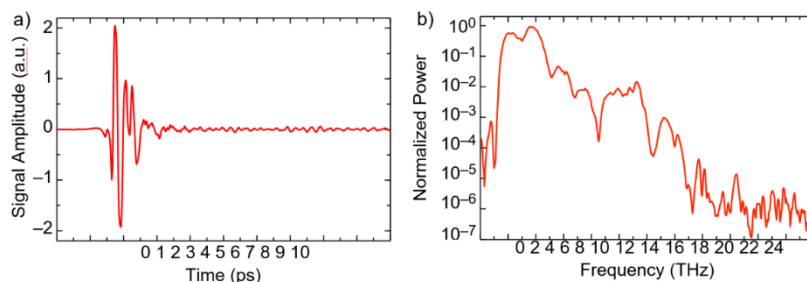

Fig 5: THz time-domain signal (a) and the corresponding power spectrum (b) of the compact terahertz setup.

### 3.3 Dye-Sensitized Solar Cells: Simulation of the Impedance, Experimental Validation and Parameter Extraction

In this bachelor thesis, impedance spectra of six different dye-sensitized solar cells (DSCs) provided by the industrial partner H. Glass were measured at different bias voltages and compared with each other. In addition, a simulation model for electrochemical impedance spectroscopy (EIS) was formulated based on differential equations (describing a diffusion model) and RC elements (representing a transmission line model). Subsequently, this model was implemented into PECSIM, a software for the simulation of DSCs, in order to extract the cells' parameters.

Students: L. Basler, E. Comi Category: Bachelor Thesis  
 Mentoring: D. Bernhardsgrütter, M. Schmid  
 Handed in: 08.06.2018

DSCs represent an alternative technology to conventional silicon-based devices. The potential advantage of DSCs lies in their low production costs due to cheap raw materials. Especially for niche applications they are considered a promising solution. Electrochemical impedance spectroscopy (EIS) is a measurement technique that has proven to be extremely useful for the characterization of DSCs. EIS allows to determine the impedance of a device at different frequencies. With the help of the measured impedances, charge transport and undesired recombination processes inside a DSC can be investigated and consequently optimized.

In the context of this work, a simulation model for impedance spectroscopy is developed and implemented in PECSIM. It is based on diffusion and transmission line models of the dye-sensitized solar cell. Additionally, DSCs with different material properties are examined via EIS measurements and compared to each other. This is done using a measuring device, Paios which was developed by the company Fluxim AG at the ZHAW. The main goal of this work is to simulate the measured data in PECSIM and to extract the key properties of the cells.

Using extensive parameter fitting it could be demonstrated that the EIS simulation tool is able to accurately match measured spectra. Through this

process, the new version of PECSIM was not only validated, but also shown to be capable of deriving informative properties of DSCs, such as transport and recombination resistances. This work sets the foundation for further simulation-based optimization of the DSC technology, with the prospect that these cells can be produced commercially in the near future.

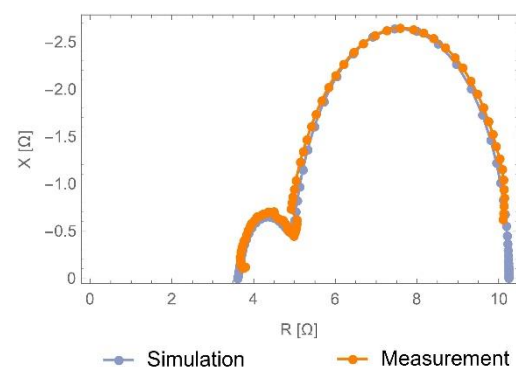

Fig. 1: EIS simulation and measurement of a DSC shown in a Nyquist plot. The PECSIM simulation yields a curve that perfectly matches the measurement result.

#### Student Project:

L. Basler, E. Comi, Dye-Sensitized Solar Cells: Simulation of the Impedance, Experimental Validation and Parameter Extraction, Supervisors: D. Bernhardsgrütter, M. Schmid, Bachelor Thesis in Energy and Environmental Engineering.

### 3.4 Improved Luminous Efficacy in Organic Light-Emitting Diodes Thanks to a Newly Developed Diffusion Layer

**Within the research project FlexOLED materials, measuring instruments and simulation software were developed to improve the energy efficiency of organic light emitting diodes (OLEDs).**

**Contributors:** M. Regnat, T. Beierlein, B. Blülle, M. Diethelm, M. Jazbinsek, K. Lapagna, K. Pernstich, B. Ruhstaller

**Partners:** Avantama AG, PV-LAB (EPFL), ZPP (ZHAW), Fluxim AG

**Funding:** KTI

**Duration** 2015–2018

More and more screens, mobile phone displays and, more recently, lighting solutions are being manufactured from organic light-emitting diodes (OLEDs). Thin layers of various semiconductor materials are combined in such a way that the charge carriers, moved when a voltage is applied, recombine and generate light. Some of this radiation, however, is totally reflected due to the different refractive index between the individual layers and remains trapped within the OLED.

Within the scope of the FlexOLED project, new materials have been developed to help emit more of the light generated in an OLED into the environment. An additional layer was developed for this purpose, which is applied between the carrier substrate and the OLED itself and scatters the light. On the one hand, nanoparticles are embedded in this scattering layer to increase the effective refractive index, and on the other, embedded micro particles also ensure effective scattering of light even at large angles, which would otherwise be totally reflected. The innovative litter layers were developed by the company, Avantama and subsequently tested in the ZHAW laboratory.

The development of such a scatter layer would hardly have been possible without suitable simulation software. Simulations were used to find the optimal material parameters. Depending on the structure of the OLED, different layer thicknesses and particle concentrations are required for optimum results. In cooperation with the company, Fluxim, new software algorithms were developed at the ICP with which these optimal material parameters could be found.

The development of such a scatter layer would hardly have been possible without suitable simulation software. Simulations were used to find the optimal material parameters. Depending on the structure of the OLED, different layer thicknesses and particle concentrations are required for optimum results. In cooperation with the company, Fluxim, new software algorithms were developed at the ICP

with which these optimal material parameters could be found. By manufacturing our own OLEDs with the internal scattering layers, their development could be significantly improved. By testing the layers under real conditions, weak points were detected and the material combinations could be further optimized. A particularly important component of an OLED is a transparent conductor layer. The required material is difficult to separate in good quality.

In the course of this project, a new type of transparent conductor was developed at EPFL which does not require the valuable precious metal indium. The remaining layers of the OLED were produced in the ICP's own laboratory. The internal scattering layers influence the angles at which the light of the OLED is emitted. In general, this radiation behaviour is an important criterion and in this thesis a measuring device was developed to measure the angle-resolved radiation behaviour of OLEDs. For this purpose, a prototype was developed at the ZHAW (ICP and ZPP), which was further developed to series maturity by Fluxim (Fig. 1). The success of this project was sometimes due to the fact that the entire development chain was covered by the partners involved, i.e. from material development and optimization of material parameters through simulation to the production and characterisation of own samples to verify the expected specifications.



Fig. 1: From prototype to product: The PHELOS measuring instrument developed in the project for determining the angle-resolved radiation behaviour of OLEDs.



### 3.5 Limits of Triplet Harvesting in Fluorescent Organic Light Emitting Diodes

The objectives of this research project are, first, to investigate the mechanism of triplet harvesting in state-of-the-art fluorescence based exciplex organic light emitting diodes (OLEDs) and, second, to investigate and quantify the efficiency limit and roll-off at high excitation as well as the degradation phenomena during prolonged operation of these OLEDs. An electro-optical drift-diffusion model is used to describe and predict the characteristics of the OLEDs.

Contributors: M. Regnat, K. Pernstich, B. Ruhstaller

Partners: Jang-Joo Kim group from Seoul National University, Korea

Funding: SNF

Duration: 2016–2019

Fluorescence based OLEDs have particular advantages compared to phosphorescence based OLEDs: lower cost of materials because no precious metals (Ir, Pt) have to be used, long device lifetime, a narrow emission spectra leading to saturated colors, and a better intellectual property landscape. One major drawback, however, is the low efficiency related to the low singlet exciton yield of 25%. This low efficiency can be significantly increased when the OLED materials are capable of converting (non-radiative) triplet states to emissive singlet states. In this project we use the abilities at the ICP for advanced OLED device characterization (Paios) and advanced OLED device simulation (Setfos) to investigate the highly-efficient TADF OLEDs with fluorescent emitters, provided by the team of Prof. Jang-Joo Kim from Seoul National University.

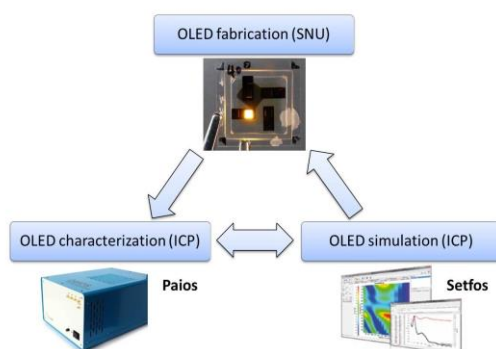

Fig. 1: Project approach for the investigation of high efficient state-of-the-art fluorescent exciplex OLEDs.

Due to the all-in-one measurement tool Paios and new in-house developed add-on measurement setups at ICP, we were able to characterize these OLEDs with several different methods, such as standard current density – voltage curve, impedance and capacitance – voltage measurements, as well as angle-dependent electroluminescence (EL)

spectra and temperature-dependent transient EL measurements. Based on the OLED characterization results, an electrooptical drift-diffusion OLED model was established with the simulation software Setfos. Fig. 2 shows the good agreement of measurement and simulation for the example of the temperature-dependent transient EL decay behavior of the OLED after voltage turn-off.

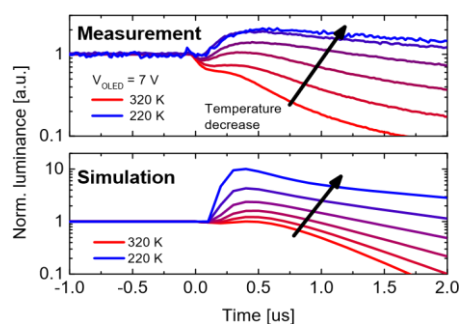

Fig. 2: Measured and simulated temperature-dependent transient EL decay behavior of the OLED after voltage turnoff ( $t = 0$  us).

In Fig. 2 a slower EL decay for decreasing temperature after voltage turn-off ( $t = 0$  us) is observed, which is a typical behavior for OLEDs with triplet harvesting mechanism. The deviation of the peak height in the simulation to the measurement in Fig. 2 indicates that the electro-optical model parameters have to be adjusted and/or new mechanisms added, which is under current investigation. At the end of the project a comprehensive model should be established to describe and predict the OLED efficiency limit and degradation phenomena of this state-of-the-art fluorescence based exciplex OLED, leading to the realization of improved TADF OLEDs.

M. Regnat, K.P. Pernstich, S. Züfle, B. Ruhstaller, *Analysis of the bias-dependent split emission zone in phosphorescent OLEDs*. ACS Applied Materials & Interfaces 10 (37), 31552 (2018)

## 4 Sensor and Measuring Systems

Nowadays almost every object of everyday life carries a functional coating. The coating not only determines the appearance but also affects its properties such as its scratch or corrosion resistances. In order to ensure the quality of coatings, its thickness, homogeneity, material composition and adhesion properties have to fulfill certain standards. Previously, these coating properties often could only be determined in rather few individual samples. To minimize errors this often resulted in coatings being too thick, thus wasting material.

Lock-in thermography is a relatively new, non-destructive and non-contact testing method. In this case, a surface is thermally excited over a temporally changing heat flux. The resulting thermal radiation is recorded by infrared sensors and evaluated by means of computer algorithms. This allows one, for example, to detect invisible surface defects, whereby the depth range can be varied over the applied modulation frequency.

At ICP, lock-in thermography has been further developed for several years in the framework of numerous R&D projects. For example, in cooperation with the industrial partners J. Wagner, Oerlikon Metco and AkzoNobel the CoatMaster was developed to measure coating thicknesses. In addition, ICP uses lock-in thermography to detect skin diseases.



Andreas Bachmann

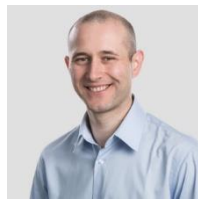

Mathias Bonmarin



Daniel Fehr



Lorenz Holzer



David Schaltegger

An-



Matthias Schmid



Andreas Witzig

## 4.1 Skinobi – an Affordable Sensor to Track Skin Condition and Age

**Skinobi is an affordable sensor that tracks skin condition and age. It can be used at home by everyone to improve their skin condition over time. The sensor is based on the measurement of the skin surface temperature over time during active cooling.**

Contributors: Ch. Kirsch, A. Zubiaga, G. Boiger, M. Bonmarin

Partners: opus néoi GmbH

Funding: Innosuisse

Duration: 2018–2020

The skin is the first barrier of our organism and plays therefore a very important role. Like every other organ, the skin can be affected by a variety of diseases. Although very few of them are lethal, they can have a dramatic psychological impact for those affected. In addition, in our modern society, the skin reflects our health and youth and plays a very important social role. Today, thousands of different products are available over the counter to either treat specific skin disorders or to simply preserve the skin from aging and external aggressions.

Our goal is to help every customer assessing the efficacy of his or her skin treatment or preferred daily lotion. The measuring instrument will be wirelessly connected to a smartphone or tablet, and it will allow the user to easily retrieve important skin parameters. To achieve this task, we will use an innovative sensor developed specifically for measuring the thermal characteristics of human skin. Thermal conductivity, heat capacity or density are very good markers of the skin condition and they correlate with physiological parameters like the hydration or the epidermis thickness. Up to now, the few apparatus on the market are either reserved to trained professionals or they are closer to “lifestyle gadgets” than to scientific-based devices. We want to close this gap and offer an affordable yet reliable device for home use.

While some preliminary work has already been achieved within the framework of an SATW project, substantial scientific and technical developments are still required to reach the proof-of-concept stage. The goal of this project is to develop a fully working prototype in terms of both hardware and software, that can be used as a demonstrator. Technical developments will be achieved in close collaboration with ZHAW while the experimental validation will take place at the University Hospital Basel. Finally, a first batch of 100 devices will be produced by opus néoi GmbH and delivered to key opinion leaders and potential strategic partners.

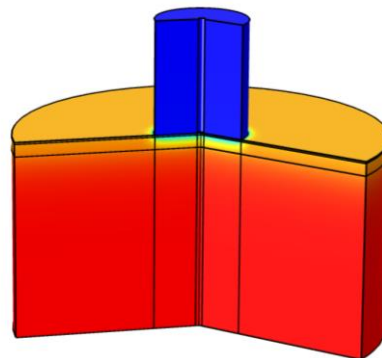

Fig. 1: Computational simulation of the measurement process. A cold aluminum block is brought into contact with the skin surface whereas the transient skin surface temperature is monitored using a thermopile sensor.

## 4.2 3D-Thermography for Medical Applications

Thermography can be used to detect and classify local heat anomalies in the skin. In this project the conventional 2D thermography was extended for 3D investigations. The 3D reconstruction is then based on a geometric analysis of 2D stereo image pairs, where different algorithms were implemented and compared. For image acquisition, an experimental set-up was created that can simultaneously record images in the visible spectrum (vis: approx. 380 - 780 nm) and in the long-wave infrared range (IR: approx. 7 - 14  $\mu\text{m}$ ). The combination of vis and IR data significantly increases the quality of the 3D thermal images.

Contributors: C. Bader, L. Holzer, M. Bonmarin  
 Partners: Prof. A. Navarini, Uni Basel  
 Funding: -  
 Duration: 2018–2019

In order to reconstruct 3D body surfaces, (multiple) 2D stereo images are required, which capture the same object from different angles. In this pilot project, a thermographic experimental set-up was designed so that different 3D reconstruction methods can be performed with the same set-up. Currently, the experimental set-up includes two RGB cameras (Logitech C270) and two longwave infrared cameras (FLIR Lepton 3.5) fixed at a constant angle on a swivel arm. Image acquisition can be controlled by any third-party device (Python interpreter). Thanks to the flexible control software, it would also be possible to equip the test set-up with additional sensors in order to completely map the surfaces of larger bodies.

The 3D reconstruction using Matlab, ReCap, Fiji and OpenCV is based on the identification of identical points in stereo image pairs. Due to the geometric relationship, the corresponding 3D coordinates of prominent pixels can be calculated using triangulation. Numerous points then become a so-called point-cloud, which can be converted into a polygonal 3D surface (Figure 1a). For conventional vis images, this 3D reconstruction can be reliably performed. Different algorithms like 'structure from motion' and 'multi view stereo vision' are used.

In contrast, the 3D reconstruction of IR thermal images poses a major challenge due to the relatively small number of distinctive image features. The 3D reconstruction of thermal images is therefore carried out in two steps. In a first step, a conventional 3D reconstruction with vis image data is generated (Figure 1a). In a second step, the IR images are superimposed on the already created 3D reconstruction (Figure 1b).

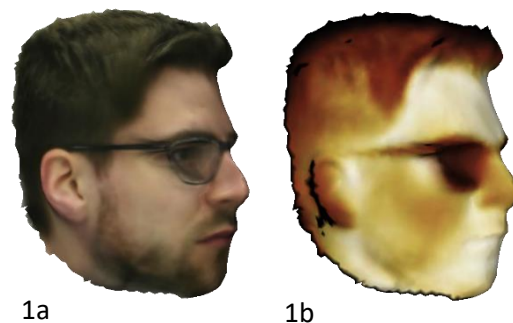

Figure A: 3D reconstruction of vis (1a) and IR image data (1b)

In the future, such 3D thermal images can be used for basic investigations of thermal skin anomalies based on state-of-the-art data analysis methods (Big Data / Artificial Intelligence).

### 4.3 Portable Device for Early Diagnosis of Lymphedema

Contributors: D. Fehr, A. Bachmann, B. Bonmarin

Funding: Innosuisse

Duration: 2018–2019

The probability of developing lymphedema until the end of life is about 30% after breast cancer treatment - and this is only one of the possible risk factors. Millions of people are therefore at increased risk of developing lymphedema. In this disease, the function of the lymphatic system is permanently disturbed, causing e.g. irreversible swelling of the arms if appropriate treatment is not initiated in time. This slows down the swelling or even stops it completely. An early diagnosis of the disease is therefore central. Nevertheless, there is currently no standardized, widely available method that allows regular and reliable monitoring of people with an increased risk.



Fig. 1: Left: Autarkic hand tool with battery. Top right: Display. Middle: Measurement opening. Bottom right: Measured value versus actual marker concentration.

In this work, a suitable method for the early diagnosis of lymphedema is being developed in collaboration with the Institute of Pharmaceutical Sciences at ETH Zurich. It consists of a fluorescent marker, which is injected into the skin of the patient, and a simple measuring device for medical conditions, which can determine the degradation rate of the marker by means of the fluorescence intensity. If the rate of degradation is reduced, there is a suspicion of developing lymphedema. Ideally, patients will be able to use this method to monitor their lymphatic system independently and regularly and, if suspected, be able to consult a specialist at an early stage. In various preliminary projects, a suitable fluorescent marker and a first portable measuring device with optical sensor technology for quantifying the fluorescence signal were developed. For this purpose, the existing optics (Fig. 2) were supplemented by a self-sufficient control electronics and operating element and installed in a compact housing (Fig. 1). With this hand-held device, the method could already be validated in various experiments.

The measuring device is currently being revised and realized as a portable sensor, i.e. the previous

handheld device shrinks to the size of a wristwatch. For this purpose, the optics are developed from scratch, because the existing optics cannot be further reduced due to the principle. First attempts are very promising. With comparable sensitivity the optics could be reduced considerably. At the same time, a suitable smartphone app will be implemented, which allows model-based measurement data evaluation in addition to sensor operation. The model:

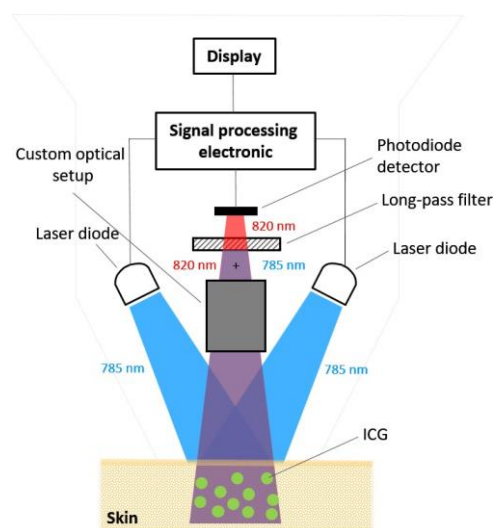

Fig. 2: Optical and electronic components of the handset.

#### Literature:

[1] A. Polomska et al., *Minimally invasive method for the point-of-care quantification of lymphatic vessel function*, JCI Insight, 4(4), 2019.

#### Paper:

A. Fallah, M. Ghajari, Y. Safa, *A computational framework for the study of dynamic delamination in morphing composite blades and wings*, Submitted to Journal Engineering Structures.

#### 4.4 DermalR – Increasing the Capabilities of Dermatoscopy Using Thermal Imaging Sensors

**We want to extend the abilities of standard epiluminescence microscopy by adding dynamic thermal imaging capabilities. Giving the physicians additional information about the temperature of the lesion will drastically improve the differential diagnostic of various skin disease. This project will deliver a fully working, clinically tested diagnostic device, ready to enter the market and increase FotoFinder products portfolio**

Contributors: Ch. Bader, A. Bachmann, M. Bonmarin

Partners: FotoFinder Systems GmbH

Funding: EUROSTARS

Duration: 2018–2021

The project content is confidential.

## 4.5 Modelling of Ground-Source Coil Tanks for Thermal Analysis

**Dynamic simulation is often used for the planning of heat pump heating systems in combination with ground-source loops. On this basis, variant decisions are made and control parameters are optimised. The present work helps to adequately map complex ground-source coils and to make them accessible to digital planning.**

Contributors: T. Frei, A. Witzig

Partners: E-Zeit Ingenieure, NM Numerical Modeling GmbH, Vela Solaris AG

Funding: Masterarbeit

Duration: 2018–2019

Heat pump heating systems often use the ground as a heat source. In addition to ground-source loops, there is also the concept of the ground-source coil, which also includes the "E-Tank" geothermal heat storage tank patented in 2016. Depending on size and design, geothermal storage tanks are suitable for seasonal storage.

The thermally activated soil is a storehouse with a very large mass and inertia. A simple long-term calculation of the E-tank is already possible with the commercial planning tool Polysun [1]. However, the short-term heat exchanger effects and the detailed geometry of the ground-source coil are not shown. In order to improve the predicted system behaviour, a three-dimensional simulation model based on the finite element method is created. The multiphysics software SESES developed at ICP is used. The physical formulas and parameters were implemented on the basis of a simple transient test model. The influence of the calculation time step and the finite element size on the simulation result could be tested [2].

Temperatures and energy flows were recorded at different areas of the model as well as in a pipeline. The simulation model could be calibrated on the basis of the field measurement data of a test arrangement in Chemnitz. A satisfactory correlation with the measurement data from the year 2016 was found.

The knowledge gained is not continuously included in the dynamic annual simulation, as it still requires

a lot of computing power in the current implementation. The fully parameterizable simulation model currently consists of 33 million elements. A solution for the reduction of the computational effort was theoretically shown but not yet implemented. The success of this work lies in the fact that such large simulation areas can be mapped. The new simulation model is an excellent tool for the further development and optimization of the E-tank and other systems with ground-source coils.

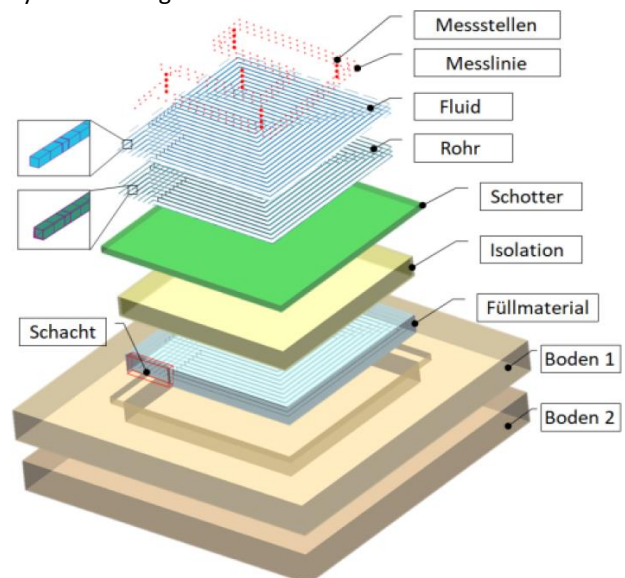

Figure: E-Tank ground-source coils in exploded view. Pipe routing and layer structure of the soil are mapped in detail for the simulation.

### References:

[1] [www.polysunsoftware.com](http://www.polysunsoftware.com)

[2] T. Frei: Modelling and simulation of a new type of earth register storage (E-tank) for thermal analysis. Master's Thesis ICP-ZHAW, Juli 2018.

## 4.6 Digital Twin: Using Building Information Modelling (BIM) for Simulation of Building-Integrated Energy Systems

Contributors: A. Witzig, D. Schaltegger

Partners: Swisscom Industrial IoT, Meier Tobler AG, BS2 AG, Vela Solaris AG

Funding: Innosuisse

Duration: 2018–2020

Digitalization has reached the building industry: Building Information Modelling (BIM) is the first step in the geometric capture of building data and, in combination with modified planning processes, offers great potential for comprehensive, optimized planning. Due to the technological possibilities, many devices are also connected to the Internet (Internet of Things, IoT). However, digital plans and IoT log data remain largely unused for the energetic optimisation of buildings.

Both BIM and IoT offer great prospects of success for the simulation: new international standards and open interfaces allow the use of geometry data as input for the numerical models. Measurement data from sensors are available for the validation of calculations and for the calibration of simulation parameters. Ultimately, the transfer of the optimum control determined in the simulation to the heating system promises both time-saving and a reduction in uncertainties. Technological progress makes it possible to optimize work processes, such as the extensive use of remote maintenance for heat pump systems.

Several projects are underway at the ICP that deal with the concrete implementation of the digital twin in the building sector. On the one hand, the numerical models are developed which represent the heating and cooling systems with sufficient accuracy and determine the simulation parameters on the basis of the integration of measurement results. On the other hand, organizational challenges are addressed: it is observed that the control and regulation of heat pump systems in practice often do not follow the originally planned control algorithms. For this reason, planning values for energy consumption and the degree of self-use of the photovoltaic system cannot be achieved. Technical innovations (direct programming of the controllers from the planning data [1]) or an adaptation of the processes and business models [2] can contribute to the solution.

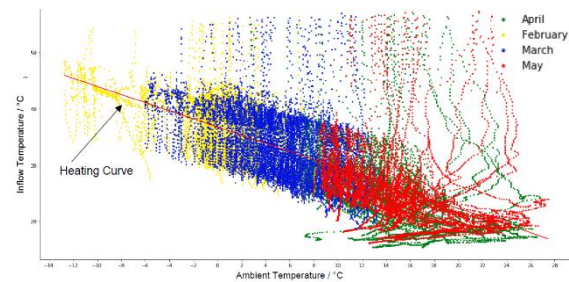

Fig. 1

The overriding goal for the researchers at the ICP as well as the industrial partners involved is energy optimization. However, stricter energy laws also result in financial incentives: the energy performance promised in the building application must be verified by measurements in the completed building. Deviations are already detected by simulations with BIM data during the construction phase. This minimizes risks and saves money.

### References:

- [1] R. Grosskopf: Heat pumps directly driven via simulation software. Bachelor Thesis ICP-ZHAW, June 2017.
- [2] H. Sotnikova: Predictive IoT-maintenance for heat pump systems. Master Thesis ICP-ZHAW, October 2018.



## 4.7 Measuring Thermal Coating Resistance of Turbine Blades

**Thermal barrier coatings (TBC) protect turbine blades against heat and mechanical stress. Due to uncontrollable process parameters, the thermal coating resistance varies during the production of turbine blades. Currently, the resistance is measured by a visible inspection of microscopic cross-section images. This is very labour intensive and requires the destruction of production samples. Therefore, we investigated a new, fast and non-destructive measurement approach using impulse thermography. We showed that it is possible to reliably measure the thermal coating resistance if the effusivity of the substrate is known.**

Contributors: A. Bariska, N. Reinke, S. Hauri  
 Partners: Winterthur Instruments AG, Oerlikon Metco AG  
 Funding: CTI  
 Duration: 2015–2018

TBC consist of two layers: first a bond coat (nickel alloy) is applied to the steel substrate and then the functional top coat (yttrium stabilized zirconia, YSZ) is applied onto the bond coat. The two most important factors governing the protective function are the porosity and the thickness of the YSZ coating. In order to compare the barrier properties of two different coatings these two parameters have to be quantitatively combined. This combination is, however, difficult as the influence of the porosity on the thermal barrier property is dependent on the microstructure of the porosity.

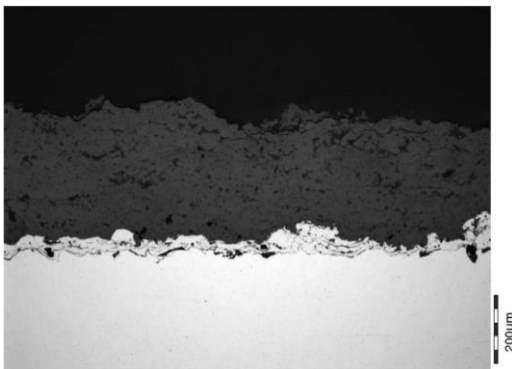

Fig. 1: Polished cross-section image of a TBC consisting of a bond coat (middle) and the top coat (top) on a steel substrate (bottom). Source: Oerlikon Metco AG, Wohlen.

Instead of using microscopic cross-section images to determine the porosity and the thickness, as shown in Fig. 1, we used the impulse-thermography-based CoatMaster measurement system to directly measure the thermal properties of the TBC. We assume, as a simple approximation, a constant heating power on the outside and a constant cooling power on the inside of the turbine blade. The temperature difference  $\Delta T$  and the heat flow  $\vartheta$  through the coat-

ing are constant and related, via a material parameter called thermal coating resistance  $R_{th}$ , with the formula  $\vartheta = \Delta T/R_{th}$ . To make the values independent of the area we have to use the heat flux density in  $W/m^2$ . The thermal coating resistance is therefore given in  $(Km^2)/W$ . With the CoatMaster measurement system, we can directly measure the thermal propagation time of a coating  $\tau$  (unit: s). If the thermal effusivity  $E$  (units:  $J/(m^2K\sqrt{s})$ ) of the coating is known and the thermal effusivity  $E$  (units:  $J/(m^2K\sqrt{s})$ ) of the coating is known and the thermal propagation time is measured, the thermal coating resistance can be calculated with  $R_{th} = \sqrt{\tau}/\epsilon$ .

In a series of measurements we could show that it is possible to reliably measure the thermal coating resistance with a fast and nondestructive measurement approach. A selection of measurements is given in Tab. 1.

Sample	Average Coat Thickness	Top Coat Porosity (image analysis)	Thermal Coating Resistance (absolute)	Thermal Coating Resistance (relative)
270	160µm			
284	140µm	4%	169 µKm <sup>2</sup> /W	75%
285	270µm	4%	225 µKm <sup>2</sup> /W	100%
286	328µm	1.9%	-	-
287	150µm	11.3%	221 µKm <sup>2</sup> /W	98%
288	228µm	11.1%	317 µKm <sup>2</sup> /W	141%
289	356µm	11%	-	-
290	75µm	15%	242 µKm <sup>2</sup> /W	108%
291	340µm	17.9%	-	-
292	280µm	15%	576 µKm <sup>2</sup> /W	256%

Tab. 1: Thermal coating resistance measured with the Coat-Master system.

## 4.8. Viscosity Control Technologies for the Controlled Application of Coating Materials

The control electronics and its associated DSP algorithms, which are used to run viscosity sensors, were adapted to a novel inline sensor technology. Next, a flow loop system was developed and set up to test the inline sensors under controlled conditions and to perform a complete characterization of the sensors. Once the flow-loop is extended by an automated thinner dosing, it becomes a fully automatic viscosity control system, which guarantees a constantly high coating quality and thus enables the user to make substantial savings in material, plant and working time.

Contributors: D. Fehr, U. Vögeli, A. Bariska, S. Hauri, N. Reinke  
 Partners: Rheonics GmbH  
 Funding: Innsuisse  
 Duration: 2016-2018

A control unit based on a DSP (Digital Signal Processor) was developed to evaluate the sensor signals of a new type of inline viscometer. The starting point was an electronic system from a previous project and its associated software. The analog front end and the algorithms were adapted to the new inline viscosity sensors.

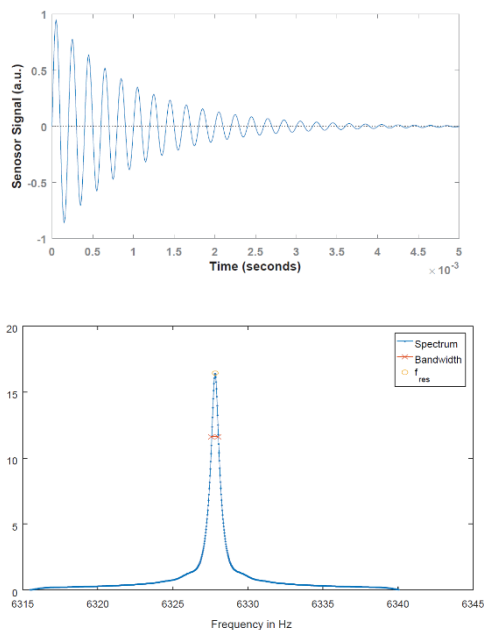

Figure 1: Characteristic decaying oscillation of a mechanical resonator for viscosity determination (top) and the associated spectrum from which the viscosity of the fluid can be deduced by determining the center frequency and bandwidth (bottom))

The underlying measuring principle can be described as follows: The electronics causes the mechanical resonator submerged in fluid to oscillate. The resonator's resonant frequency and damping depend on the density and viscosity of the fluid. Figure 1 shows a typical oscillation waveform of the

sensor, i.e. an exponentially decaying oscillation. The DSP electronics determines the resonant frequency and damping based on the spectrum of the decay waveform, which is showed in in Figure 1, too.

Parallel to the control electronics, a test system (flow loop) has been designed and implemented (Figure 2). It resembles a typical wet coating process: Conveying of coating material and thinner, a mixer, circulation with the inline viscosity sensor and a tap that simulates the application of the coating material. With the flow loop and the control electronics described above, the viscosity sensors can be tested and characterized under typical operating conditions. Furthermore, the system enables the development of an inline viscosity control system in which thinners are automatically mixed with the coating materials. With this technology a constant viscosity can be guaranteed in industrial coating plants.

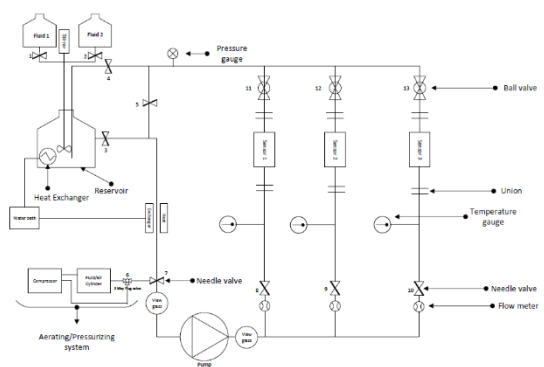

Figure 1: Flow-loop test system.

# 5 Teaching

## 5.1 Gamification in Teaching

The increasing digitalization is noticeable in many areas of everyday life and has also changed the area of teaching. A further increase in this area can be expected and is actively promoted in ZHAW's "Education and Digital Transformation" strategy.

Various methods have been established to replace or supplement traditional classroom teaching, such as support for lectures using digital media (videos, wikis, MOOCs, clickers, quizzes, etc.) and learning platforms such as Moodle, OLAT, or Mahara. Especially in technical fields, it is common to hold practice lectures in which students have to solve exercises. In this area of solving classical exercises, there are hardly any approaches yet to complement and support face-to-face teaching with digital methods.

In a pilot project on "digital teaching methods", a web application (e-Exercises or e-Ex in short) was developed to close the digitalization gap in the area of solving exercises. The web application uses elements found in computer games that lead to a positive experience, such as collecting points or special trophies.

The starting point for the development of the app was that a large part of the exercises in the physics class take place in self-study and that the lecturer has little control over the learning progress of the students. This situation will be exacerbated by the increasing digitalisation of teaching. Students also often consult the sample solution and think they have mastered the exercises, but experience shows that the concepts of the sample solutions can rarely be transferred to other problems. The exercises are often perceived as too difficult, which can have a demotivating effect on the students.

With the new app, the exercises are distributed online. Points are awarded for correct solutions and a hint system supports solving the exercises, whereby each hint costs points. Through the points system, students receive live feedback on their personal learning success, and lecturers on the learning success of the class (learning analytics). A key feature of the app is the ability to comment on the sample solution if the exercise could not be solved. Through this written reflection, deepened learning takes place. This feature is a unique selling point of the app, since a more in-depth examination of the sample solution does practically not occur in classical classroom settings.

An initial trial run was successful. Initial feedback from the students provides the app with a good report (linked article is in German only). An extensive evaluation was designed in cooperation with the PHZH Evaluation Centre and is scheduled to take place in the fall semester of 2019.

The web application developed by us is a new and unique tool in the e-didactics landscape and offers real added value for digital forms of teaching. The app can be used in many subjects, especially in physics and statistics with R, as well as in all subjects in which the exercises deliver a numerical result. Adjustments to the requirements for mathematics are planned and will be implemented soon.

## Structure of the Web App

Figure 1 shows a screenshot of the web app as it was used in semester weeks 13 and 14 in subject PHSVS1. This page appears after a student has logged in and shows the so-called Live Learning Progress as a Key Performance Indicator. In the boxes on the top one can see the points already achieved (in this case 7 points); the trophies and kudos (= a score of honorary degrees) are further features that are not yet implemented. On the left there is a selection menu, which leads to the tasks of the individual weeks.

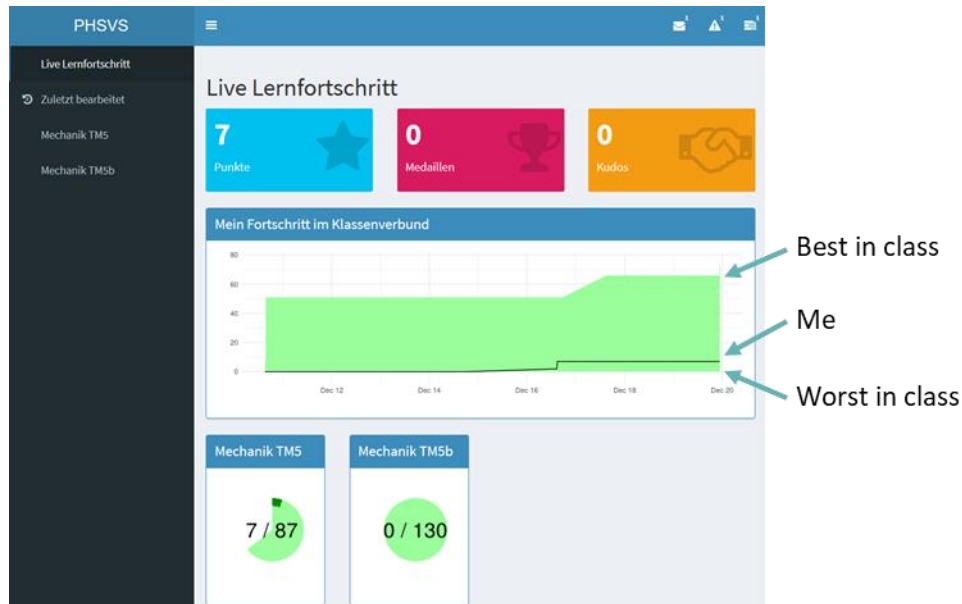

Figure 1 Screenshot of the page "Live Learning Success". In addition to the points already achieved, the own learning success is shown in comparison to fellow students as well as an overview of the finished and unfinished exercises for each week.

The presentation of one's own points compared to those of fellow students is central to the app. This creates a certain group pressure, which should have a motivating effect. By concealing the individual identities, the group pressure should not become too great.

In this diagram one can also see the points already scored each week, and the points which can still be scored. This clear representation should also create a certain amount of pressure, as it can be seen at any time how much work still needs to be done before the end of the week. But it is also rewarding to see that a week has been completed.

Figure 2 shows the weekly view for the topic "Mechanics TMS". There are four exercises to be solved and for each exercise the point score is displayed. In the first task 5 points have already been scored (dark green bar). In the second task a hint was used, which reduced the number of points to be reached (missing piece of cake in task 2).

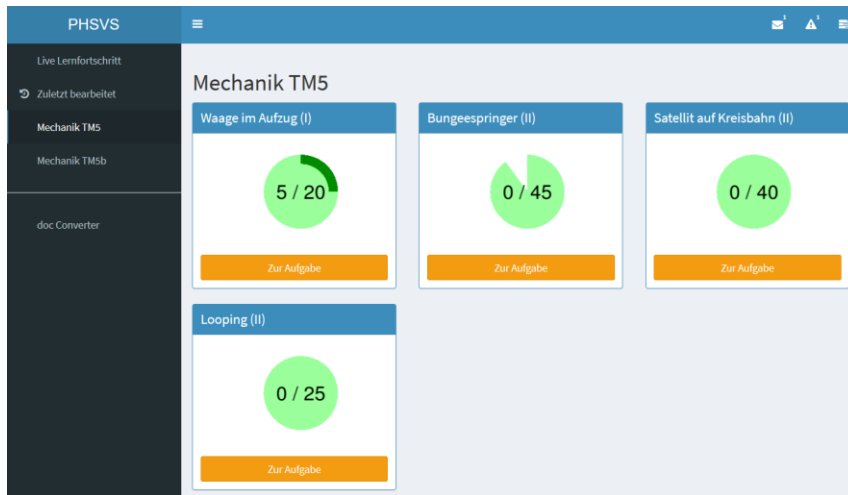

Figure 2 Weekly view with the individual exercises. For each exercise it becomes clear how many points you have already scored (dark green bar), how many points can still be scored (light green area) and how many points you have been awarded by using clues (missing piece of cake in bungee jumper task).

Figure 3 shows the view of an exercise, where the introductory text can also include an image or a video. An exercise can contain any number of sub-exercises (a), b), c), ...). Each sub-exercise has its own text and a field for transmitting the numerical solution. If the user enters the correct solution, the points will be credited, in this case 30 points.

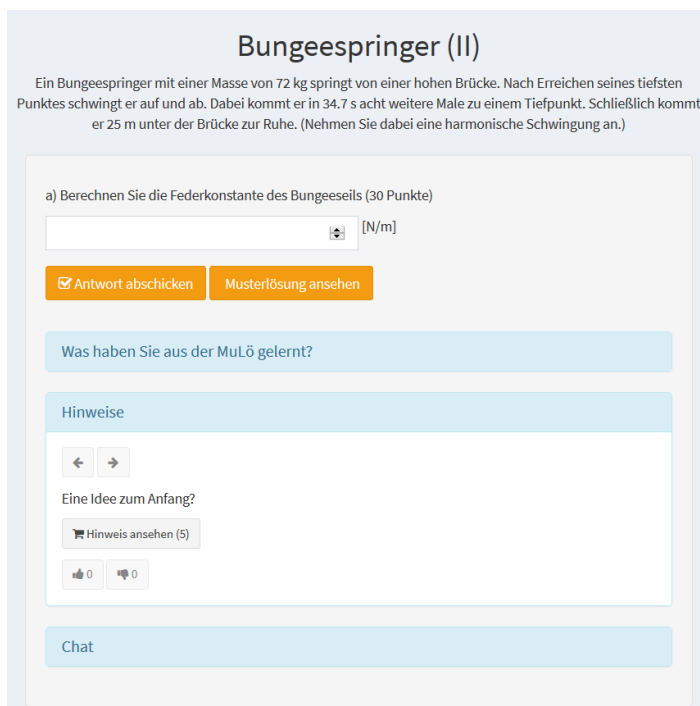

Figure 3: View of an exercise, where the introductory text can also include an image or a video. An exercise can consist of any number of sub-exercises (a), b), ...). Each sub-exercise has its own text, as well as a field for transmitting the solution. If the sample solution is viewed, a field is displayed for transmitting the reflection of the sample solution. If hints are defined for the exercise, they are displayed. A chat within the class is also available for each sub-exercise.

If hints have been defined for a sub-exercise, they are displayed. Each hint is associated with costs, in this example, 5 points. The hints are free of charge after the exercise has been solved correctly or the sample solution has been purchased. The hints can also be rated positively or negatively by students and help the teacher to improve the hints.

A chat is available for each sub-exercise in which the students can help each other. Kudos (= a score of honorary degrees) should be assigned for helpful answers in the chat; this feature has not yet been implemented.

If the solution cannot be solved despite hints and the chat, one can look at the sample solution. Of course, no more points will be awarded for this exercise unless a detailed description of what has been learned from the sample solution is provided. The teacher reads the written reflection of the student and can award points or report errors in the reflection of the sample solution. This in-depth reflection practically does not take place in class and is a unique selling point of the app.

The mechanism for reflection on the sample solution promises a significant increase in learning success. By writing, one often translates loose thoughts into concrete words and since the teacher reads the reflection, misconceptions can be recognized and corrected.

In addition to the question type described above, in which the result comprises a number, further question types are available. For example, there are multiple-choice questions, free text questions (which currently cannot be checked automatically) and complex question types in which students can enter and execute R-code. The R-Code is checked automatically and is used especially in the field of statistics. Because the web app was programmed in-house, based on an existing project (tguishiny, developed by G. De Cilia, B. Meindl, M. Templ), the app can easily be extended to other question types in order to meet the respective wishes and requirements.

## **Conclusion**

From my work with the web application, I have come to the conclusion that the web application will prove its worth in teaching, i.e. it will encourage students to solve more exercises on the one hand, and enable in-depth learning. The app is also met with great interest by many colleagues.

Kurt Pernstich, ICP

## 5.2 Seamless Learning: Project Cluster and Management of the IBH Lab

Within the framework of the International Lake Constance University IBH, so-called labs have been offered since 2016. These are networked projects that are linked in terms of content and are carried out in a larger, topic-specific research consortium. Together with the Center for Innovative Didactics (ZID) of the ZHAW School of Management and Law, the ICP manages the Seamless Learning Lab. The four-year project comprises the development, implementation and evaluation of a Seamless Learning concept in various disciplines with university and industry partners.



Figure 1: Group photo at the internal annual meeting of the Seamless Learning Lab.

The following partners belong to the project consortium:

- ZHAW with the institutes ICP and IAMP from the School of Engineering, ZID from the School of Management and Law and LCC from Applied Linguistics
- HTWG Konstanz with the Faculties of Computer Science and Life Science as well as the Department of Health Informatics
- Albstadt-Sigmaringen University of Applied Sciences, Faculty of Life Sciences
- FHS St. Gallen, Institute for Modelling and Simulation
- University of St. Gallen, Institute for Business Education
- Interstate University of Applied Sciences Buchs (NTB), Institute for Production Measurement Technology, Materials and Optics
- Baden-Wuerttemberg Cooperative State University, Ravensburg
- University of Konstanz, Department of Teaching, Writing Centre
- University of Liechtenstein, Department of Didactics and Applied Linguistics

- University of Education Vorarlberg, didactics natural sciences

Concepts for teaching and learning across borders and contexts are developed together. This takes place against the background of technological progress, which places new demands on teaching and learning scenarios. Regular events are held in which interim results are presented and further networking is cultivated. Last year the Seamless Learning Conference 2018 was held in Winterthur and preparations are currently underway for the "Day of Teaching" planned with the theme "Designing Flexible Learning at Universities".

**Use of modern technologies**

Learning and teaching is undergoing profound change. Learners do not need much more than a mobile device with Internet access, a sheet of paper and a pen to learn anywhere and at any time. Learning resources are ubiquitously available (e.g. as OERs<sup>1</sup>, MOOCs<sup>2</sup>). Computer-assisted collaborative learning is easier than ever (European Commission 2012: 9). The boundaries between formal and informal learning are becoming increasingly blurred. The technologies that fuel this change are evolving rapidly. The requirements of lifelong learning pose challenges for the design of adequate technology-supported teaching/learning scenarios.

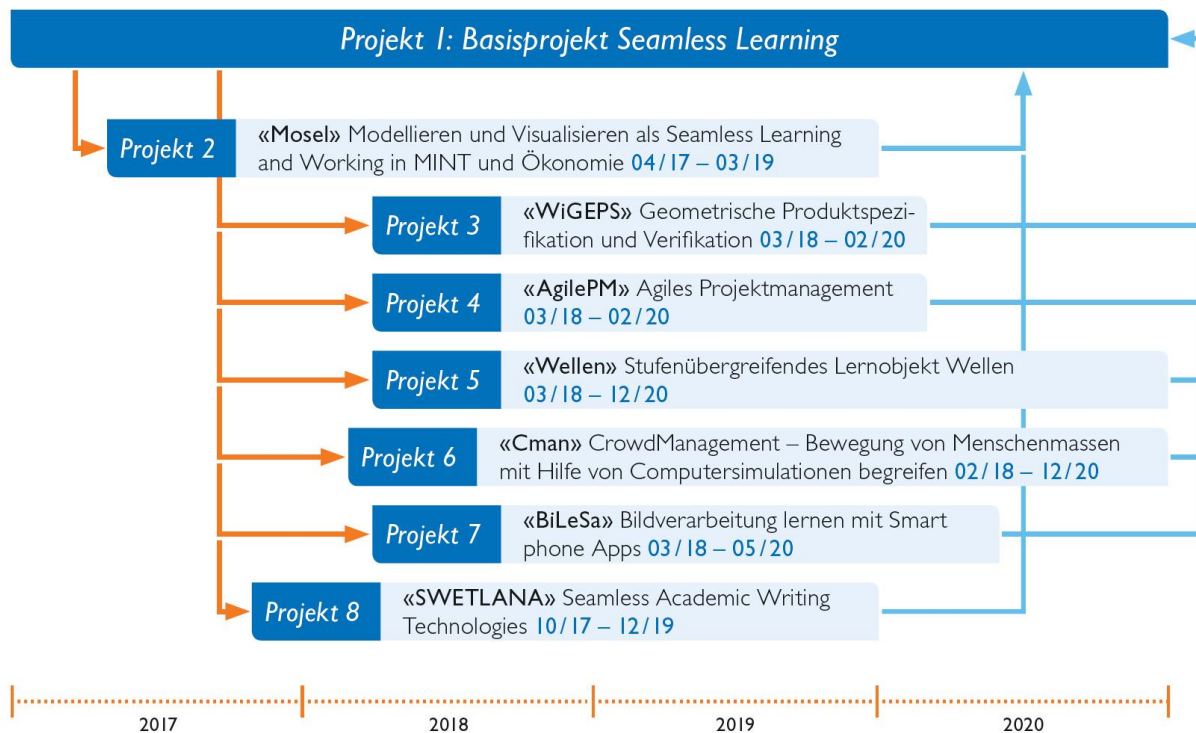

Figure 2: Project overview. The ICP is actively involved in the steering committee and in projects 2, 5, 6 and 7.

**Adapted didactic concepts**

It is known from theory and practice that the technology made available has little effect in itself. Both teachers and learners need to learn to deal with it, i.e. to be empowered. A conclusive (subject-) didactic concept is also required. A further, often even greater obstacle in the career of (lifelong) learners in the 21st century are the still existing breaks in the learning biography - exemplarily from school to training or university and in the profession with corresponding further training. The transfer and the transitions are limited.



The concept of "Seamless Learning" provides a framework to address the technological and didactic challenges outlined above and to enable lifelong, seamless learning across educational contexts. The aim of this lab is therefore to conceptualise, develop, implement, evaluate and optimise seamless learning for various areas (in individual projects in the fields of MINT, social sciences and key qualifications such as project management). While individual dimensions of interfaces for Seamless Learning have already been identified, successful pilots in various fields have been lacking so far. The IBH Lab makes this possible, especially with regard to educational contexts, educational phases and educational levels across borders and to the various fields of application in practice.

Matthias Schmid, ICP

<https://www.seamless-learning.eu>

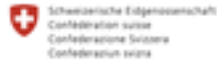

# Appendix

## A.1 Students Projects

D. BAUMANN, F. HOERNLIMANN, *Erhöhung der Energieeffizienz eines neuartigen Holzvergasungs-systems für Eukalyptus bei Melides, Portugal*. Betreuer: G. Boiger, A. Fassbind, Firmenpartner: Stiftung Alberta Nova, Projektarbeit Systemtechnik.

J. BAUMGARTNER, A. MORGADO, *Smartwatch for optical detection of impaired lymphatic vessel function*. Betreuer: M. Bonmarin, N. Reinke, Firmenpartner: Institute of Pharmaceutical Sciences at ETH Zurich, Bachelorarbeit Systemtechnik.

D. BEE, J. GIGER, *A new hand-held imaging device to investigate the thermal properties of the human skin*. Betreuer: G. Boiger, M. Bonmarin, Firmenpartner: Dermolockin GmbH, Projektarbeit Systemtechnik.

N. BOATENG, M. FLÜELER, *Android-Based Medical Image Processing*. Betreuer: M. Löser, M. Bonmarin, Firmenpartner: Dermolockin GmbH, Bachelorarbeit Electrotechnik.

C. BRÄNDLE, A. SCHÖNENBERGER, *Temperaturüberwachung an Blattoberflächen von Pflanzkulturen durch Infrarotdetektoren*. Betreuer: T. Hocker, T. Bergmann, Projektpartner: Meyer Orchideen AG, Projektarbeit Maschinentechnik.

Y. CORNAZ, *Weiterentwicklung eines neuartigen Holzvergasungssystem in Grandola (Portugal) zur Vergasung des lokalen Eukalyptus*. Betreuer: G. Boiger, A. Fassbind, Firmenpartner: Stiftung Alberta Nova, Bachelorarbeit Maschinentechnik.

S. EHRAT, *Theoretische und experimentelle Untersuchungen von Abkühlprozessen im sub-kW Bereich*. Betreuer: T. Hocker, Projektpartner: Wöhner AG, Vertiefungsarbeit Masterstudiengang.

A. FRIEDRICH, M. LAURIA, *Development and characterization of 3D skin tissue models with optical methods*. Betreuer: M. Bonmarin, M. Jazbinsek, Firmenpartner: Rainbow Photonics, Bachelorarbeit Systemtechnik.

J. GIANOTTI, *CFD basierte Optimierung eines Oel-Tanks*. Betreuer: G. Boiger, Firmenpartner: Regloplas AG, Bachelorarbeit Maschinentechnik.

R. HALDEMANN, F. HEUBERGER, *Erhöhung der Energieeffizienz eines Holzvergasungssystem in Portugal, durch thermo-dynamische 1D Modellierung*. Betreuer: G. Boiger, Firmenpartner: Stiftung Alberta Nova, Bachelorarbeit Maschinentechnik.

S. HELFENSTEIN, S. SATKUNARAJA, *Numerical thermal model of the human skin*. Betreuer: M. Bonmarin, G. Boiger, Firmenpartner: Dermolockin GmbH, Bachelorarbeit IT.

I. HERZIG, F. SCHOLPP, *Simulation und Experimentelle Validierung von Elektro-Statistischen Beschichtungsprozessen*. Betreuer: G. Boiger, Firmenpartner: Wagner International AG, Projektarbeit Systemtechnik.

C. HOCH, *Entwicklung und Prototypbau eines neuartigen Konservierungsverfahrens für Fluide*. Betreuer: G. Boiger, Bachelorarbeit Maschinentechnik.

F. JOHN, *Optimierung des Kristallisationsverhaltens von Schokoladenprodukten durch eine geeignete Kühlmethode*. Betreuer: T. Hocker, Projektpartner: P. Abegglen, H. U. Vollenweider, Bachelorarbeit Maschinentechnik.

P. KHODADUST, *Neuartige Kombination von CFD und Machine Learning Technologie*. Betreuer: G. Boiger, Bachelorarbeit IT.

S. LANDOLT, *Application of Novel Machine Learning Software to Predict Powder Coating Phenomena*. Betreuer: G. Boiger, Bachelorarbeit IT.

D. MEIER, *Modellierung von Uj-Kennlinien für Festoxidbrennstoffzellen unter Berücksichtigung der Brenngasverweilzeit*. Betreuer: T. Hocker, Projektpartner: Hexis AG, Masterarbeit Masterstudiengang.

G. QUADRI, A. BACHMANN, *A new hand-held imaging device to investigate the thermal properties of the human skin*. Betreuer: M. Bonmarin, M. Löser, Firmenpartner: Dermolockin GmbH, Bachelorarbeit Systemtechnik.

L. RUCKSTUHL, *Analysis of the calibration procedure of the Medyria velocity sensor based on thermo-fluidic CFD-models*. Betreuer: T. Hocker, Projektpartner: Medyria AG, Vertiefungsarbeit Masterstudiengang.

S. SPIRIG, *Untersuchung der optimalen Platzierung von Temperatursensoren zur akkuraten Oberflächentemperaturmessung*. Betreuer: T. Hocker, Vertiefungsarbeit Masterstudiengang.

J. STOLL, F. ZIMMERLI, *Weiterentwicklung des thermischen Managements einer neuartigen Holzvergasungsanlage*. Betreuer: G. Boiger, Projektarbeit Energie- und Umwelttechnik.

## A.2 Scientific Publications

S. ALTAZIN, C. KIRSCH, E. KNAPP, A. STOUS, B. RUHSTALLER, *Refined drift-diffusion model for the simulation of charge transport across layer interfaces in organic semiconductor devices*. J. of Appl. Phys. 124 (13), 135501, 2018.

S. ALTAZIN, L. STEPANOVA, J. WERNER, B. NIESEN, C. BALLIF, B. RUHSTALLER, *Design of perovskite/crystalline-silicon monolithic tandem solar cells*. Optics express 26 (10), A579-A590, 2018.

F. ANZENGRUBER, F. ALOITAIBI, A. GHOSH, L. KAUFMANN, B. MEIER, L. FRENCH, M. BONMARIN, A. NAVARINI, *Thermography: High sensitivity and specificity diagnosing contact dermatitis in patch testing*. Allergy International, in press (2018).

D. BRUNNER, H. KHAWAJA, M. MOATAMEDI, G. BOIGER, *CFD modelling of pressure and shear rate in torsionally vibrating structures using ANSYS CFX and COMSOL multiphysics*. Int. Journal of Multi-physics, 12 (4), 349-358, 2018.

D. BURNAT, G. NURK, L. HOLZER, M. KOPECKI, A. HEEL, *Lanthanum doped strontium titanate-ceria anodes: deconvolution of impedance spectra and relationship with composition and microstructure*. J. Power Sources. 385 (2018) 62–75. doi:10.1016/j.jpowsour.2018.03.024.

L. CAPONE, P. MARMET, L. HOLZER, J. DUJC, J. O. SCHUMACHER, A. LAMIBRAC, F. N. BUECHI, J. BECKER, *An ensemble Monte Carlo simulation study of water distribution in porous gas diffusion layers for proton exchange membrane fuel cells*. ASME Journal of Electrochemical Energy Conversion and Storage, 15 (2018) 031005 <https://doi.org/10.1115/1.4038627>.

P. CENDULA, L. STEIER, P. LOSIO, M. GRÄTZEL, J. O. SCHUMACHER, *Analysis of optical losses in a photoelectrochemical cell : a tool for precise absorptance estimation*. Advanced Functional Materials. 28(1), pp. 1702768, 2018. Available from: <https://doi.org/10.1002/adfm.201702768>.

M. DIETHELM, L. PENNINGCK, S. ALTAZIN, R. HIESTAND, C. KIRSCH, B. RUHSTALLER, *Quantitative analysis of pixel crosstalk in AMOLED displays*. J. of Information Display, 1-9, 2018.

J. Dujc, A. Forner-Cuenca, P. Marmet, M. Cochet, R. Vetter, J. O. Schumacher, P. Boillat, *Modelling the effects of using gas diffusion layers with patterned wettability for advanced water management in proton exchange membrane fuel cells*. Journal of Electrochemical Energy Conversion and Storage 15(2), 2018. Available from: <https://doi.org/10.1115/1.4038626>.

- D. FLUHR, S. ZÜFLE, B. MUHSIN, R. ÖTTKING, M. SEELAND, R. ROESCH, U. S. SCHUBERT, B. RUHSTALLER, S. KRISCHOK, H. HOPPE, *Aluminum electrode insulation dynamics via interface oxidation by reactant diffusion in organic layers*. *physica status solidi (a)* 125, 23, 1800474, 2018.
- S. JENATSCH, S. ALTAZIN, P.-A. WILL, M. NEUKOM, E. KNAPP, S. ZÜFLE, S. LENK, S. REINEKE, B. RUHSTALLER, *Quantitative analysis of charge transport in intrinsic and doped organic semiconductors combining steady-state and frequency-domain data*. *J. App. Phys.* 124, 10, 105501, (2018).
- S. JENATSCH, M. REGNAT, R. HANY, M. DIETHELM, F. A. NÜESCH, B. RUHSTALLER, *Time-dependent pin structure and emission zone in sandwich-type light-emitting electrochemical cells*. *ACS Photonics*, 2018.
- C. U. JEONG, B. J. KANG, S. H. LEE, S. C. LEE, W. T. KIM, M. JAZBINSEK, W. YOON, H. YUN, D. KIM, F. ROTERMUND, O. P. KWON, *Yellow-Colored Electro-Optic Crystals as Intense Terahertz Wave Sources*. *Advanced Functional Materials* 28, 1801143, 2018.
- B. J. KANG, S. H. LEE, W. T. KIM, S. C. LEE, K. LEE, G. BENACCHIO, G. MONTEMEZZANI, M. JAZBINSEK, O. P. KWON, F. ROTERMUND, *New Class of Efficient Terahertz Generators: Effective Terahertz Spectral Filling by Complementary Tandem Configuration of Nonlinear Organic Crystals*. *Advanced Functional Materials* 28, 1707195, 2018.
- L. M. KELLER, L. HOLZER, *Image-Based Upscaling of Permeability in Opalinus Clay*. *J. Geophys. Res. Solid Earth*. 123 (2018) 285–295. doi:10.1002/2017JB014717.
- S. C. LEE, B. J. KANG, J. A. LEE, S. H. LEE, M. JAZBINSEK, W. YOON, H. YUN, F. ROTERMUND, O. P. KWON, *Single Crystals Based on Hydrogen-Bonding Mediated Cation-Anion Assembly with Extremely Large Optical Nonlinearity and Their Application for Intense THz Wave Generation*. *Advanced Optical Materials* 6, 1701258, 2018.
- S. J. LEE, B. J. KANG, M. H. SHIN, S. C. LEE, S. H. LEE, M. JAZBINSEK, H. YUN, D. KIM, F. ROTERMUND, O. P. KWON, *Efficient Optical-to-THz Conversion Organic Crystals with Simultaneous Electron Withdrawing and Donating Halogen Substituents*. *Advanced Optical Materials* 6, 1700930, 2018.
- C. MEIER, D. MEIER, F. VANDERCROYSE, T. HOCKER, *Lagrangian model using CFD flow data to predict the current-voltage characteristics of a solid oxide fuel cell repeat unit*. *The International Journal of Multiphysics*, 12, 393–411, 2018.
- M. NEUKOM, S. ZÜFLE, S. JENATSCH, B. RUHSTALLER, *Opto-electronic characterization of third-generation solar cells*. *Science and technology of advanced materials* 19 (1), 291-316, 2018.
- M. NEUMANN, O. FURAT, D. HLUSHKOU, U. TALLAREK, L. HOLZER, V. SCHMIDT, *On microstructure-property relationships derived by virtual materials testing with an emphasis on effective conductivity*. 2018, *Sim. Sci./Commun. Comput. Inf. Sci. (CCIS)*, Springer. 145–158. doi:10.1007/978-3-319-96271-9\_9.
- D. PENNER, L. HOLZER, *Characterization and modelling of structure and transport properties of porous ceramics*. *cfi Ceramic Forum International*, 95 (\*) E27-E32, doi: 10.21256/zhaw-3574.
- L. PENNINCK, M. DIETHELM, S. ALTAZIN, R. HIESTAND, C. KIRSCH, B. RUHSTALLER, *Modelling crosstalk through common semiconductor layers in AMOLED displays*. *J. of the Society of Information Display* 671, 2018.
- M. PRESTAT, J. SOARES COSTA, B. LESCOF, S. RIOUAL, L. HOLZER and D. THIERRY, *Cathodic Corrosion of Zinc under Potentiostatic Conditions in NaCl Solutions*. *ChemElectroChem*, 5, 1203-1211, doi: 10.1002/celec.201701325.
- U. PUC, A. ABINA, A. JEGLIC, A. ZIDANSEK, I. KASALYNAS, R. VENCKEVICIUS, G. VALUSIS, *Spectroscopic analysis of melatonin in the terahertz frequency range*. *Sensors* 18, 4098, 2018.
- M. REGNAT, K. P. PERNSTICH, S. ZÜFLE, B. RUHSTALLER, *Analysis of the bias-dependent split emission zone in phosphorescent OLEDs*. *ACS applied materials & interfaces* 10 (37), 31552-31559, 2018.

A. ROVERE, Y. G. JEONG, R. PICCOLI, S. H. LEE, S. C. LEE, O. P. KWON, M. JAZBINSEK, R. MORANDOTTI, L. RAZZARI, *Generation of high-field terahertz pulses in an HMQ-TMS organic crystal pumped by an ytterbium laser at 1030 nm*. Opt. Express 26, 2509-2516, 2018.

M. H. SHIN, S. H. LEE, B. J. KANG, M. JAZBINSEK, W. YOON, H. YUN, F. ROTERMUND, O. P. KWON, *Organic Three-Component Single Crystals with Pseudo-Isomorphic Cococrystallization for Nonlinear Optics and THz Photonics*. Advanced Functional Materials 28, 1805257, 2018.

B. SIYAHHAN, M. BOLDRINI, S. HAURI, N. REINKE, G. BOIGER, *Procedure for experimental data assessment for numerical solver validation in the context of model based prediction of powder coating patterns*. Int. Journal of Multiphysics, 12 (4), 373--292, 2018.

L. WANG, S. JENATSCH, B. RUHSTALLER, C. HINDERLING, D. GESEVIČIUS, R. HANY, F. NÜESCH, *Organic Salt Semiconductor with High Photoconductivity and Long Carrier Lifetime*. Adv. Func. Materials 28, 16, 1705724, 2018.

### A.3 Book Chapters

S. ALTAZIN, L. PENNINGCK, B. RUHSTALLER, *OLED Outcoupling technologies: concepts, simulation, and implementation*. Handbook of Organic Light-Emitting Diodes, Springer Japan, 2018.

### A.4 News Articles

D. NEESER, G. BOIGER, Tüftler macht Strom aus Holz. In: *Der Landbote*, August 2018.

### A.5 Conferences and Workshops

S. ALTAZIN, T. BEIERLEIN, M. DIETHELM, R. FERRINI, R. HIESTAND, C. KIRSCH, T. OFFERMANS, L. PENNINGCK, M. REGNAT, B. RUHSTALLER, *Electrothermal simulation of large-area semiconductor devices*. International Conference on Simulation of Organic Electronics and Photovoltaics (SimOEP 2018), Winterthur, Switzerland.

S. ALTAZIN, C. KIRSCH, E. KNAPP, A. STOUS, B. RUHSTALLER, *Refined drift-diffusion model for the simulation of charge transport across layer interfaces in organic semiconductor devices*. Applied Mathematics and Simulation for Semiconductors (AMaSiS 2018), Berlin, Germany.

G. BOIGER, *Eliminating anomalies of CFD model results of the powder coating process by refining aerodynamic flow-particle interaction and by introducing a dynamic particle charging model*. 3rd International Conference on Fluid Dynamics & Aerodynamics, Berlin, 2018.

G. BOIGER, B. SIYAHHAN, M. BOLDRINI, *Enhancing the understanding of complex phenomena in powder coating, by applying Eulerian-Lagrangian simulation methodology*. 13th International Conference of Multiphysics, Krakow, 2018.

D. BRUNNER, K. HAEUSELER, S. KUMAR, H. KHAWAJA, M. MOATAMED, G. BOIGER, *Impact of fouling on mechanical resonator-based viscosity sensors: comparison of experiments and numerical models*. 13th International Conference of Multiphysics, Krakow, 2018.

D. FEHR, *Early diagnostics of lymphedema using a near-infrared fluorescent marker and custom portable detection device*. Swiss Society for Biomedical Engineering Annual Meeting, Biel, 2018.

- E. KNAPP, *Physical model for inductive loop and negative capacitance in perovskite solar cells*. Asia-Pacific Hybrid and Organic Photovoltaics Conference (AP-HOPV), Kitakyushu, Japan, January 29, 2018.
- E. KNAPP, *Modeling negative capacitance and inductive loop in perovskite solar cells*. Intl. Conference on Simulation of Organic Electronics and Photovoltaics (SimOEP'18), Winterthur, Switzerland, Sept 4-6, 2018.
- E. KNAPP, *Physical model for inductive loop and negative capacitance in perovskite solar cells*. Intl. Conference on Perovskite Solar Cells and Optoelectronics (PSCO), Lausanne, Switzerland, September 30, 2018.
- M. NEUKOM, *Opto-Electronic Characterization of Third Generation Solar Cells*. Intl. Summer School on Nanosciences & Nanotechnologies (ISSON), Thessaloniki, Greece, June 30, 2018.
- J. PIOTROWSKI, A. HÄFFELIN, R. VETTER, J. O. Schumacher, *Analysis and extension of a PEMFC model*, 15th Symposium on Modeling and Validation of Electrochemical Energy Devices (ModVal 2018), Aarau, Switzerland, April 12-13, 2018. Available from: <https://doi.org/10.21256/zhaw-3599>.
- U. PUC, T. BACH, M. KRAJEWSKI, C. MEDRANO, M. JAZBINSEK, *Ultrabroadband terahertz time domain spectroscopy based on organic crystals*. 8th International Workshop on Terahertz Technology and Applications, Kaiserslautern, Germany, March 20-21, 2018.
- B. RUHSTALLER, *Modeling Pixel Crosstalk through Common Semiconducting Layers in AMOLED Displays*. DFF Work Group Meeting, Gundersheim, Germany, Jan 25, 2018.
- B. RUHSTALLER, *Reliable electrical characterization and modelling of organic LEDs and solar cells with doped layers and internal interfaces*. Intl. Conference on Simulation of Organic Electronics and Photovoltaics (SimOEP'18), Winterthur, Switzerland, Sept 4-6, 2018.
- B. RUHSTALLER, *Electronic, ionic and optical perovskite solar cell modeling and experimental validation*. NanoGe Fall'18 Meeting PeroMod, Torremolinos, Spain, Oct 22-26, 2018.
- J. O. SCHUMACHER, *Elektromobilität mit Brennstoffzellen*, Podium Nachhaltige Mobilität, Hochschule Rapperswil, Switzerland, March 2018.
- R. VETTER, J. O. SCHUMACHER, *An open implementation of a two-phase PEMFC model in MATLAB*, 15th Symposium on Modeling and Validation of Electrochemical Energy Devices (ModVal 2018), Aarau, Switzerland, April 12-13, 2018.
- R. VETTER, J. O. SCHUMACHER, *A new open-source PEMFC simulation tool for easy assessment of material parameterizations*, 15th Symposium on Modeling and Validation of Electrochemical Energy Devices (ModVal 2018), Aarau, Switzerland, April 12-13, 2018. Available from: <https://doi.org/10.21256/zhaw-3621.k>

## A.6 Teaching

- T. BERGMANN, T. HOCKER, *Thermische Energiesysteme, FS18*, Bachelor of Science.
- G. BOIGER, *Fluid- & Thermodynamik I für EU - Vorlesung & Praktikum FS18*, Bachelor of Science.
- G. BOIGER, *Numerik für IT II – Vorlesung & Praktikum, FS18*, Bachelor of Science.
- G. BOIGER, *Numerik für IT I – Vorlesung & Praktikum, HS18*, Bachelor of Science.
- G. BOIGER, *Physik und Systemwissenschaften für AV II – Praktikum, FS18*, Bachelor of Science
- G. BOIGER, *Advanced Thermodynamics, HS18*, Master of Science in Engineering.

- G. BOIGER, *Thermofluidodynamik Modellentwicklung mit OpenFoam I*, HS18, Master of Science in Engineering
- G. BOIGER, *Two Phase Flow with Heat and Mass Transfer*, FS18, Master of Science in Engineering.
- M. BONMARIN, *Numerik für IT I – Vorlesung & Praktikum*, FS18, Bachelor of Science.
- M. BONMARIN, *Physik für Systemtechnik II – Vorlesung & Praktikum*, FS18, Bachelor of Science.
- D. FEHR, *Mathematik: Analysis 1 für IT*, FS18, Bachelor of Science.
- A. HEEL, T. HOCKER, *Abgas- und Abwasserbehandlung*, HS18, Bachelor of Science.
- T. HOCKER, *Fluid- und Thermodynamik 1 – Vorlesung und Praktikum*, FS18, Bachelor of Science.
- T. HOCKER, *Fluid- und Thermodynamik 2 – Vorlesung und Praktikum*, HS18, Bachelor of Science.
- T. HOCKER, *Systemphysik für Aviatik 1 – Praktikum*, HS18, Bachelor of Science.
- T. HOCKER, *Systemphysik für Aviatik 2 – Praktikum*, FS18, Bachelor of Science.
- M. JAZBINSEK, *Physik für Energie und Umwelttechnik 1 – Vorlesung & Praktikum*, FS18, Bachelor of Science.
- M. JAZBINSEK, *Physik für Energie und Umwelttechnik 2 – Vorlesung und Praktikum*, HS18, Bachelor of Science.
- E. KNAPP, *Math for Aviation - Applied Numerics - FS18*, Bachelor of Science.
- E. KNAPP, *Mathematik: Numerik für Energie- und Umwelttechnik- FS18*, Bachelor of Science.
- C. KIRSCH, *MND2 – Mathematik: Numerik und Differenzialgleichungen 2 – FS18*, Bachelor of Science.
- C. KIRSCH, *MAE2 – Mathematik: Analysis für Ingenieure 2 – FS18*, Bachelor of Science.
- C. KIRSCH, *MANIT1 – Mathematik: Analysis 1 – HS18*, Bachelor of Science.
- C. KIRSCH, *MNUM – Mathematik: Numerische Methoden – HS18*, Bachelor of Science.
- K P. PERNSTICH, *Physik und Systemwissenschaften für Verkehrsingenieure 1 - HS18*, Bachelor of Science.
- K P. PERNSTICH, *Physik und Systemwissenschaften für Verkehrsingenieure 2 - FS18*, Bachelor of Science.
- B. RUHSTALLER, *Applied Photonics - HS18*, Master of Science in Engineering.
- B. RUHSTALLER, *Physik und Systemwissenschaften für Verkehrsingenieure 1 - HS18*, Bachelor of Science.
- B. RUHSTALLER, *Physik und Systemwissenschaften für Verkehrsingenieure 2 - FS18*, Bachelor of Science.
- J. O. SCHUMACHER, *Analysis für Ingenieure 4 - FS18*, Bachelor of Science.
- J. O. SCHUMACHER, *Analysis für Ingenieure 3 - HS18*, Bachelor of Science.
- J. O. SCHUMACHER, *Multiphysics Modelling and Simulation HS18*, Master of Science in Engineering.
- J.O. SCHUMACHER, *Numerical Simulation of Solar Cells FS18*, Master Online Photovoltaics.

## A.7 Spin-off Companies



**NM Numerical Modelling GmbH**  
The engineering company, CH-Thalwil

[www.nmtec.ch](http://www.nmtec.ch)

Numerical Modelling GmbH works in the field of Computer Aided Engineering (CAE) and offers services and simulation tools for small and medium enterprises. Our core competence is knowledge transfer where we bridge the gap between scientific know-how and its application in the industry. With our knowledge from physics, chemistry and the engineering sciences we are able to support your product development cycle and to conform to your time and budget constraints. We often create so-called customer specific CAE tools in which the scientific knowledge required for your product is embedded. In this form, it is easily deployed within your R&D department and supports actual projects as well as improving the skills of your staff. Ask for our individual consulting service which covers all areas of scientific knowledge transfer without obligation.



[www.fluxim.com](http://www.fluxim.com)

Fluxim is a provider of device simulation software and measurement hardware to the display, lighting and photovoltaics community worldwide. Our principal activity is the development and the marketing of the simulation software SETFOS and LAOSS, as well as the measurement platform PAIOS, PHELOS and LITOS. The combination of simulation software with measurement data allows for the determination of material and device parameters. The R&D tools are used worldwide in industrial and academic research labs for the development of devices and semiconducting materials with improved performance as well as the study of device physics.



[www.winterthurinstruments.ch](http://www.winterthurinstruments.ch)

Winterthur Instruments AG develops measurement systems for fast non-contact and non-destructive testing of industrial coatings. These measurement systems can be used to determine coating thicknesses, material parameters, e. g. porosity and contact quality, e. g. to detect delamination. The system is based on optical-thermal measurements and works with all types of coating and substrate materials. Our measurement systems provide the unique opportunity of non-contact and non-destructive testing of arbitrary coatings on substrates.



[www.nanolockin.com](http://www.nanolockin.com)

NanoLockin is developing the new benchmark technology for the detection and analysis of nanoparticles in all kinds of products. The company won the Fribourg Innovation Awards in 2018.





[www.skinobi.com](http://www.skinobi.com)

Opus Néoi is a spin-off company founded in 2016 developing Skinobi, the first reliable skin sensor for end consumers. Skinobi allows the customer to monitor the skin condition at home and recommends the ideal, customized skin care solution. It takes advantage of sophisticated algorithms via an IoT network to analyze and extract skin parameters. The innovative measurement method specifically measures the thermal transport characteristics of the skin by optical means. Thermal conductivity, heat capacity or density are very good markers of the skin's condition and correlate with physiological parameters like hydration or epidermal thickness.



[www.zarawind.com](http://www.zarawind.com)

Zarawind is a Winterthur-based ZHAW spin-off company involved in the development of an airborne wind energy system

**Feature:**

Zarawind technology aims to produce a renewable cost effective electricity from the strong and consistent wind power at high altitude. This is reachable using a rotor lifted by an aerostat at several hundred meters.

**Advantages:**

wind power is permanently available with a strong capacity. Zarawind model ensures continuous operation avoiding noisy problems, flickering, NIMBY claims and bird crash.

**Benefit:**

Ensuring a renewable electrification of off-grid regions at effective cost.

**Customers:**

One-billion persons in off-grid.

## A.8 ICP Team

Name	Function	Email
Dr. Tobias Bach	Research Associate	<a href="mailto:baht@zhaw.ch">baht@zhaw.ch</a>
Andreas Bachmann	Research Assistant	<a href="mailto:bacr@zhaw.ch">bacr@zhaw.ch</a>
Christoph Bader	Research Assistant	<a href="mailto:bado@zhaw.ch">bado@zhaw.ch</a>
David Bernhardsgrütter	Research Associate	<a href="mailto:bens@zhaw.ch">bens@zhaw.ch</a>
Dr. Gernot Boiger	Lecturer	<a href="mailto:boig@zhaw.ch">boig@zhaw.ch</a>
Marlon Boldrini	Research Associate	<a href="mailto:bolm@zhaw.ch">bolm@zhaw.ch</a>
Dr. Mathias Bonmarin	Lecturer	<a href="mailto:brni@zhaw.ch">brni@zhaw.ch</a>
Daniel Brunner	Research Assistant	<a href="mailto:brni@zhaw.ch">brni@zhaw.ch</a>
Vincent Buff	Research Assistant	<a href="mailto:buff@zhaw.ch">buff@zhaw.ch</a>
Ennio Comi	Research Assistant	<a href="mailto:comi@zhaw.ch">comi@zhaw.ch</a>
Jonas Dunst	Research Assistant	<a href="mailto:duns@zhaw.ch">duns@zhaw.ch</a>
Sandro Ehrat	Research Assistant	<a href="mailto:ehrd@zhaw.ch">ehrd@zhaw.ch</a>
Daniel Fehr	Research Associate	<a href="mailto:fehd@zhaw.ch">fehd@zhaw.ch</a>
Joël Gianotti	Research Assistant	<a href="mailto:giat@zhaw.ch">giat@zhaw.ch</a>
Robert Herrendörfer	Research Associate	<a href="mailto:herf@zhaw.ch">herf@zhaw.ch</a>
Prof. Dr. Thomas Hocker	Lecturer	<a href="mailto:hoto@zhaw.ch">hoto@zhaw.ch</a>
Dr. Lorenz Holzer	Research Associate	<a href="mailto:holz@zhaw.ch">holz@zhaw.ch</a>
Dr. Mojca Jazbinsek	Lecturer	<a href="mailto:jazb@zhaw.ch">jazb@zhaw.ch</a>
Dr. Lukas Keller	Research Associate	<a href="mailto:kelu@zhaw.ch">kelu@zhaw.ch</a>
David Kempf	Research Assistant	<a href="mailto:kempf@zhaw.ch">kempf@zhaw.ch</a>
Dr. Christoph Kirsch	Lecturer	<a href="mailto:kirs@zhaw.ch">kirs@zhaw.ch</a>
Dr. Evelyne Knapp	Research Associate	<a href="mailto:hube@zhaw.ch">hube@zhaw.ch</a>
Viktor Lienhard	Research Associate	<a href="mailto:lied@zhaw.ch">lied@zhaw.ch</a>
Philip Marmet	Research Assistant	<a href="mailto:mame@zhaw.ch">mame@zhaw.ch</a>
Dominic Neeser	Research Assistant	<a href="mailto:nees@zhaw.ch">nees@zhaw.ch</a>
Alexandra Meier	Administrative Assistant	<a href="mailto:bral@zhaw.ch">bral@zhaw.ch</a>
Vincent Michel	Research Assistant	<a href="mailto:micv@zhaw.ch">micv@zhaw.ch</a>
Jhimy Michel Rivero	Trainee	<a href="mailto:micr@zhaw.ch">micr@zhaw.ch</a>
Gaël Mourouga	Research Assistant	<a href="mailto:mouo@zhaw.ch">mouo@zhaw.ch</a>
Martin Neukom	Research Assistant	<a href="mailto:neko@zhaw.ch">neko@zhaw.ch</a>
Dr. Kurt Pernstich	Lecturer	<a href="mailto:pern@zhaw.ch">pern@zhaw.ch</a>
Dr. Uros Puc	Research Associate	<a href="mailto:pucu@zhaw.ch">pucu@zhaw.ch</a>
Markus Regnat	Research Assistant	<a href="mailto:rega@zhaw.ch">rega@zhaw.ch</a>
Prof. Dr. Markus Roos	Lecturer	<a href="mailto:roor@zhaw.ch">roor@zhaw.ch</a>
Prof. Dr. Beat Ruhstaller	Lecturer	<a href="mailto:ruhb@zhaw.ch">ruhb@zhaw.ch</a>
Dr. Yasser Safa	Research Associate	<a href="mailto:safa@zhaw.ch">safa@zhaw.ch</a>
Dr. Guido Sartoris	Research Associate	<a href="mailto:srts@zhaw.ch">srts@zhaw.ch</a>
David Schaltegger	Research Assistant	<a href="mailto:sctg@zhaw.ch">sctg@zhaw.ch</a>
Andreas Schiller	Research Assistant	<a href="mailto:scdr@zhaw.ch">scdr@zhaw.ch</a>
Dr. Matthias Schmid	Lecturer	<a href="mailto:scmi@zhaw.ch">scmi@zhaw.ch</a>
Prof. Dr. Jürgen Schumacher	Lecturer	<a href="mailto:schm@zhaw.ch">schm@zhaw.ch</a>
Bercan Siyahhan	Research Assistant	<a href="mailto:siya@zhaw.ch">siya@zhaw.ch</a>
Hanna Sotnikova	Research Assistant	<a href="mailto:sotn@zhaw.ch">sotn@zhaw.ch</a>
Dr. Fabrizio Spano	Research Associate	<a href="mailto:span@zhaw.ch">span@zhaw.ch</a>
Sebastian Spirig	Research Assistant	<a href="mailto:spii@zhaw.ch">spii@zhaw.ch</a>
Prof. Dr. Andreas Witzig	Lecturer, Head ICP	<a href="mailto:wita@zhaw.ch">wita@zhaw.ch</a>
Jakub Wlodarczyk	Research Assistant	<a href="mailto:wlod@zhaw.ch">wlod@zhaw.ch</a>
Dr. Asier Zubiaga	Research Associate	<a href="mailto:zuba@zhaw.ch">zuba@zhaw.ch</a>
Simon Züfle	Research Associate	<a href="mailto:zufe@zhaw.ch">zufe@zhaw.ch</a>

## A.9 Location

### ICP Institute of Computational Physics

Technikumstrasse 9  
 P.O. Box  
 CH-8401 Winterthur

[www.zhaw.ch/icp](http://www.zhaw.ch/icp)

#### Contact

Andreas Witzig  
 Phone +41 58 934 45 73  
[andreas.witzig@zhaw.ch](mailto:andreas.witzig@zhaw.ch)

#### Administration

Alexandra Meier  
 Phone +41 58 934 76 82  
[alexandra.meier@zhaw.ch](mailto:alexandra.meier@zhaw.ch)

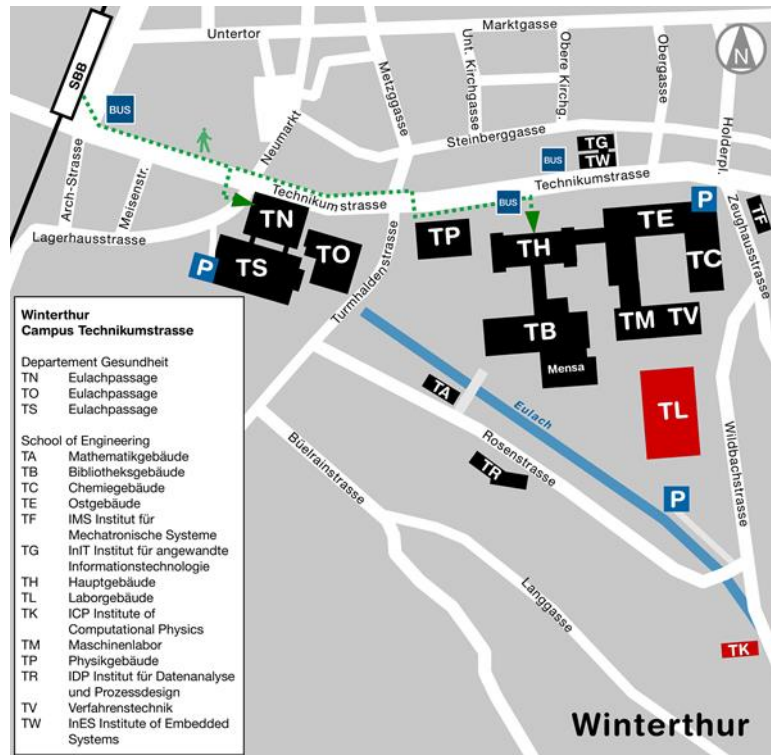

TK Building



TL Building

Zurich University of  
Applied Sciences

## **School of Engineering**

ICP Institute of  
Computational Physics

Technikumstrasse 9  
P.O. Box  
CH-8401 Winterthur

Phone +41 58 934 71 71  
[info.engineering@zhaw.ch](mailto:info.engineering@zhaw.ch)  
[www.zhaw.ch/icp](http://www.zhaw.ch/icp)